



EMUS G1 Battery Management System User Manual v1.3.0

Contents

1 Preface	4
2 Introduction	8
3 Basics	9
3.1 System structure overview	9
3.1.1 Control Unit	9
3.1.1.1 Power supply inputs	10
3.1.1.2 Data interfaces	10
3.1.1.2.1 USB	10
3.1.1.2.2 RS232	10
3.1.1.2.3 CAN	10
3.1.1.2.4 Serial cell communication interface	11
3.1.1.3 General purpose inputs and outputs	11
3.1.1.4 Current sensor inputs	11
3.1.1.5 SOC output	12
3.1.1.6 Speed sensor input	12
3.1.2 Cell Modules	12
3.1.3 Cell Communication Adapters	12
3.1.3.1 Top and Bottom Isolators	12
3.1.3.2 CAN Cell Group Modules	13
3.1.4 Current Sensor	13
3.1.4.1 Bus Bar Type	13
3.1.4.2 Closed Loop Type	14
3.1.5 Solid State Relay (obsolete product)	14
3.1.6 Smartphone Connectivity Module	14
3.1.7 Display Unit	15
3.1.8 Software	15
3.1.8.1 EVGUI Android and iOS applications	15
3.1.8.2 Control Panel	15
3.2 Functionality overview	16
3.2.1 Cell Monitoring	16
3.2.2 Current measurement	17
3.2.3 SOC estimation	17
3.2.3.1 Adjustment by cell voltage	18
3.2.4 Charging process and charging device control	18
3.2.4.1 Charging Interlock	23
3.2.5 Battery protections	23
3.2.5.1 Contactor pre-charge	25
3.2.5.2 External contactor deactivation	25
3.2.6 Power reductions	25
3.2.7 Heater and cooling fan control	26
3.2.7.1 Climate Control	26
3.2.8 DC/DC converter control	27
3.2.9 Statistics	27
3.2.10 Events	30
3.2.11 Vehicle speed measurement	31
3.2.11.1 Energy consumption calculation	31
3.2.11.2 Remaining distance estimation	32

3.2.12	Communication with external devices	33
3.2.13	Indication	33
3.2.13.1	Charging status indication	33
3.2.13.2	Buzzer	33
3.2.13.3	Low battery indication	34
4	Installation	35
4.1	Control Unit	35
4.1.1	Choosing the power supply strategy	35
4.2	Cell Modules	37
4.3	Current Sensor	39
4.4	Cell Communication Adapters	40
4.5	CAN Bus	40
4.6	Smartphone Connectivity Module	42
4.7	Display unit	42
4.8	Battery fuse	43
4.9	Contactors	43
4.9.1	Pre-charge sub-circuit	44
4.10	Charger	44
4.10.1	CAN-based chargers	44
4.10.2	Non-CAN chargers	45
4.10.3	Analog signal controlled chargers	45
4.11	Cooling fan	46
4.12	Heater	46
4.13	Indicators	47
4.14	Insulation fault detector	47
5	Configuration	49
5.1	Data interfaces	49
5.1.1	Serial	49
5.1.2	CAN	49
5.1.3	Cell communication	50
5.2	CAN Cell Group Module configuration	50
5.3	Charging process	51
5.4	Protections	53
5.5	Load power reductions	54
5.6	Current measurement	55
5.7	SOC estimation	55
5.8	Heater control	56
5.9	Cooling fan control	57
5.10	DC/DC converter control	57
5.11	Pin mapping	57
5.12	Display Unit	58
6	Maintenance	59
6.1	Calibration of Cell Module temperature sensors	59
6.2	Re-calibration of current sensor	60
6.3	Master Clear	61
6.4	Setting up password	61
6.5	Exporting and importing configuration	62
6.6	Control Unit firmware update	62

6.7	CAN Cell Group Module firmware update	63
6.8	Display Unit firmware update	63
6.9	Exporting and importing statistics	63
6.10	Changing language of the Control Panel	63
7	Technical information	65
7.1	Control Unit	65
7.1.1	Mechanical specification	65
7.1.2	Electrical characteristics	66
7.1.3	Other specifications	67
7.2	Cell Module	67
7.2.1	Mechanical specification	67
7.2.1.1	A/B type	67
7.2.1.2	Small type	68
7.2.1.3	GBS type	69
7.2.1.4	240Ah Type	69
7.2.1.5	200-400Ah type	70
7.2.1.6	CALB CAM 72Ah type	70
7.2.1.7	3A type	71
7.2.2	Electrical characteristics	71
7.2.3	Other specifications	72
7.3	Cell Communication Adapters	73
7.3.1	Mechanical specification	73
7.3.1.1	Top Isolator	73
7.3.1.2	Bottom Isolator	73
7.3.1.3	CAN Cell Group Module	73
7.3.2	Electrical characteristics	74
7.3.3	Other specifications	75
7.4	Current Sensor	76
7.4.1	Mechanical specification	76
7.4.1.1	Bus Bar Type	76
7.4.1.2	Closed Loop Type	76
7.4.2	Electrical characteristics	77
7.4.3	Other specifications	77
7.5	Solid State Relay (obsolete product)	77
7.5.1	Mechanical specification	77
7.5.2	Electrical characteristics	78
7.5.3	Other specifications	78
7.6	Smartphone Connectivity Module	78
7.6.1	Mechanical specification	78
7.6.2	Electrical characteristics	79
7.6.3	Other specifications	79
7.7	Display Unit	79
7.7.1	Mechanical specification	79
7.7.2	Electrical characteristics	79
7.7.3	Other specifications	80

1 Preface

List of Abbreviations

BMS	Battery Management System
CU	Control Unit
CM	Cell Module
CGM	CAN Group Module
CR	Carrier Return
LF	Line Feed
USB	Universal Serial Bus
CP	Control Panel
PWM	Pulse Width Modulation

List of Tables

Table 3.1: List of statistics and their descriptions	27
Table 3.2: List of events and their descriptions	30
Table 4.1: Recommended cell terminal bolt tightening torque	38
Table 4.2: Maximum bus line lengths, calculated based on the used CAN bit timing setting, considering that a twisted-pair cable with a typical propagation delay of 5 ns/m is used. L_U - maximum length of a single unterminated drop line, $\sum L_U$ - maximum length of all unterminated drop lines together.	41
Table 7.1: EMUS G1 Control Unit connector pin assignment	65
Table 7.2: EMUS G1 Control Unit electrical characteristics	66
Table 7.3: EMUS G1 Control Unit other specifications	67
Table 7.4: EMUS G1 Cell Module A/B rev.E (CM010E) terminal assignment	67
Table 7.5: EMUS G1 Cell Module A/B rev.F (CM010F) terminal assignment	68
Table 7.6: EMUS G1 Cell Module Small (CM020C) terminal assignment	68
Table 7.7: EMUS G1 Cell Module GBS (CM030B) terminal assignment	69
Table 7.8: EMUS G1 Cell Module 240Ah (CM040B) terminal assignment	69
Table 7.9: EMUS G1 Cell Module 200-400Ah (CM050B) terminal assignment	70
Table 7.10: EMUS G1 Cell Module CALB CAM 72Ah (CM060A) terminal assignment	70
Table 7.11: EMUS G1 Cell Module A/B rev.F (CM010F) terminal assignment	71
Table 7.12: EMUS G1 Cell Module electrical characteristics	71
Table 7.13: EMUS G1 Cell Module other characteristics	72
Table 7.14: EMUS G1 Top Isolator (CCA010D) wire assignment	73
Table 7.15: EMUS G1 Bottom Isolator (CCA020D) wire assignment	73
Table 7.16: EMUS G1 CAN Cell Group Module (CGM020A) cell communication wire assignment	73
Table 7.17: EMUS G1 CAN Cell Group Module (CGM020A) connector pin assignment	74
Table 7.18: EMUS G1 Top Isolator (CCA010D) electrical characteristics	74
Table 7.19: EMUS G1 Bottom Isolator (CCA020D) electrical characteristics	74
Table 7.20: EMUS G1 CAN Cell Group Module (CGM020A) electrical characteristics	74
Table 7.21: EMUS G1 Top and Bottom Isolator other specifications	75
Table 7.22: EMUS G1 CAN Cell Group Module other specifications	75

Table 7.23:EMUS G1 Bus Bar Type Dual Range Current Sensor (CS010C) wire assignment	76
Table 7.24:EMUS G1 Closed Loop Type Dual Range Current Sensor (CS020A) connector pin assignment	76
Table 7.25:EMUS G1 Dual Range Current Sensor electrical characteristics	77
Table 7.26:EMUS G1 Dual Range Current Sensor other specifications	77
Table 7.27:EMUS G1 Solid State Relay wire assignment	77
Table 7.28:EMUS G1 Solid State Relay electrical characteristics	78
Table 7.29:EMUS G1 Solid State Relay other specifications	78
Table 7.30:EMUS G1 Smartphone Connectivity Module wire assignment (applies to both BTM010B and BTM020E models)	78
Table 7.31:EMUS G1 Smartphone Connectivity Module electrical characteristics	79
Table 7.32:EMUS G1 Smartphone Connectivity Module other specifications	79
Table 7.33:EMUS G1 Display Unit connector pin assignment	79
Table 7.34:EMUS G1 Display Unit electrical characteristics	80
Table 7.35:EMUS G1 Display Unit other specifications	80

List of Figures

Figure 3.1: EMUS G1 BMS System	9
Figure 3.2: EMUS G1 Control Unit	9
Figure 3.3: Control Unit's pins - fixed in red, general purpose remappable in green, and special purpose remappable in blue	10
Figure 3.4: A standard A/B model Cell Module	12
Figure 3.5: Top and Bottom Isolators	13
Figure 3.6: CAN Cell Group Module	13
Figure 3.7: EMUS G1 Dual Range Current Sensor: (a) Bus Bar type; (b) Closed Loop type.	14
Figure 3.8: EMUS G1 Solid State Relay	14
Figure 3.9: EMUS G1 Smartphone Connectivity Module	14
Figure 3.10:EMUS G1 Display Unit	15
Figure 3.11:EMUS EVGUI Application	15
Figure 3.12:Download the app for Smartphone	15
Figure 3.13:Cell communication data flow: (a) when using Top and Bottom Isolators; (b) when using CAN Cell Group Modules.	16
Figure 3.14:Contactor pre-charge timing diagram	25
Figure 3.15:Charging indicator timing	33
Figure 3.16:Sound indicator timing	33
Figure 3.17:Low battery indicator timing	34
Figure 4.1: Correct installation of Control Unit and distribution of power supply to other EMUS G1 BMS components	35
Figure 4.2: EMUS G1 BMS power supply strategy examples	35
Figure 4.3: Correct way of wiring a cell communication daisy chain: (a) Top and Bottom Isolators; (b) CAN Cell Group Module.	37
Figure 4.4: Correct EMUS G1 BMS Cell Module installation order	38
Figure 4.5: 3M™ Scotchlok™ butt connector	39
Figure 4.6: EMUS G1 Current Sensor connection diagram. The Closed Loop type Current sensor connects identically.	39
Figure 4.7: Correct EMUS G1 Current Sensor installation: (a) Bus Bar type; (b) Closed Loop type.	39
Figure 4.8: Correct way of connecting the Top and Bottom Isolator to the Control Unit.	40
Figure 4.9: High-speed CAN network specified in ISO-11898-2 standard	40

Figure 4.10:EMUS G1 Smartphone Connectivity Module connection diagram	42
Figure 4.11:EMUS G1 Display Unit wiring	43
Figure 4.12:Connecting contactor to EMUS G1 Control Unit: (a) directly, when the rated current of the contactor coil is less than 0.5A; (b) through a relay, when when the rated current of the contactor coil is 0.5A or more.	43
Figure 4.13:Contactor pre-charge sub-circuit connection diagram	44
Figure 4.14:Correct CAN charger and charger contactor connection in respect of the battery, battery fuse, and main contactor	45
Figure 4.15:Correct connection of a non-CAN charger in respect of the battery, battery fuse, and main contactor: (a) using EMUS G1 Solid State Relay; (b) using a third-party electromechanical contactor.	45
Figure 4.16:Correct analog signal controlled charger and charger contactor connection in respect of the battery, battery fuse, and main contactor	46
Figure 4.17:Cooling fan connection diagram	46
Figure 4.18:Heater connection diagram	47
Figure 4.19:Examples of connecting visual or audial indicators to the Control Unit (left to right): an indication lamp, a self-oscillating buzzer, and an LED.	47
Figure 4.20:Example of connecting a third party insulation fault detector to the Control Unit.	48
Figure 5.1: Data Transmission to Display parameters	49
Figure 5.2: CAN communication parameters	49
Figure 5.3: Cell communication parameters	50
Figure 5.4: CAN Devices in unconfigured list	50
Figure 5.5: CAN Devices in configuration table before commit	51
Figure 5.6: CAN Devices in configuration table after commit	51
Figure 5.7: CAN Devices in configuration table after commit failed	51
Figure 5.8: Single reduction example	54
Figure 5.9: Current measurement parameters	55
Figure 5.10:"Capacity" parameter box	56
Figure 5.11:State of Charge parameters	56
Figure 5.12:Heater and Fan parameters	56
Figure 5.13:DC/DC Converted Control parameters	57
Figure 5.14:Pin mapping settings	57
Figure 5.15:Display Unit settings in Control Panel	58
Figure 6.1: External temperature sensor calibration window	60
Figure 7.1: EMUS G1 Control Unit mechanical drawing (applies both to CU010D and CU020E models). All dimensions in millimeters.	65
Figure 7.2: EMUS G1 Cell Module A/B rev.E (CM010E) mechanical drawing. All dimensions in millimeters.	67
Figure 7.3: EMUS G1 Cell Module A/B rev.F (CM010F) mechanical drawing. All dimensions in millimeters.	68
Figure 7.4: EMUS G1 Cell Module Small (CM020C) mechanical drawing. All dimensions in millimeters.	68
Figure 7.5: EMUS G1 Cell Module GBS (CM030B) mechanical drawing. All dimensions in millimeters.	69
Figure 7.6: EMUS G1 Cell Module 240Ah (CM040B) mechanical drawing. All dimensions in millimeters.	69
Figure 7.7: EMUS G1 Control Module 200-400Ah (CM050B) mechanical drawing. All dimensions in millimeters.	70
Figure 7.8: EMUS G1 Cell Module CALB CAM 72Ah (CM060A) mechanical drawing. All dimensions in millimeters.	70

Figure 7.9: EMUS G1 Cell Module 3A (CM070A) mechanical drawing. All dimensions in millimeters.	71
Figure 7.10: EMUS G1 Top Isolator (CCA010D) mechanical drawing. All dimensions in millimeters.	73
Figure 7.11: EMUS G1 Bottom Isolator (CCA020D) mechanical drawing. All dimensions in millimeters.	73
Figure 7.12: EMUS G1 CAN Cell Group Module (CGM020A) mechanical drawing. All dimensions in millimeters.	73
Figure 7.13: EMUS G1 Bus Bar Type Dual Range Current Sensor (CS010C) mechanical drawing. All dimensions in millimeters.	76
Figure 7.14: EMUS G1 Closed Loop Type Dual Range Current Sensor (CS020A) mechanical drawing. All dimensions in millimeters.	76
Figure 7.15: EMUS G1 Solid State Relay mechanical drawing. All dimensions in millimeters.	77
Figure 7.16: EMUS G1 Smartphone Connectivity Module mechanical drawing (applies to both SCM010B and BTM020E models). All dimensions in millimeters.	78
Figure 7.17: EMUS G1 Display Unit (DU010A) mechanical drawing. All dimensions in millimeters.	79

2 Introduction

The recent and ongoing development in the technology of rechargeable lithium batteries has been steadily increasing their performance and making them more safe, reliable, cheap, and easy to manufacture. All of this resulted in an increasing popularity of rechargeable lithium batteries, not only in portable consumer electronics, but also in traction, energy storage, maritime, industrial, military, aerospace and other applications, where the high energy density, negligible memory effect, low self-discharge rate, and long life cycle of lithium batteries are highly desired characteristics.

Despite the advantages, all rechargeable cells of lithium chemistry have a very strict allowed voltage range and certain charging temperature limitations. If operated outside these limits, they will fail prematurely and pose safety risks due to reactive components inside them. Also, because the mentioned applications usually require battery voltage to be significantly higher than that of a single cell, several cells have to be connected in series to attain the desired voltage. This creates another problem: since lithium chemistry cells are very intolerant to overcharging, they do not have a natural equalization mechanism when connected in series (such as gassing in lead acid batteries), and any disbalance of charge between the cells will amplify with each cycle of operation if no countermeasures are taken, rapidly decreasing the usable capacity of the whole battery pack, and potentially causing its premature failure. In order to overcome these problems and to fully exploit the advantages of rechargeable lithium batteries, it is necessary to use an intelligent battery management system that can autonomously monitor the battery parameters at individual cell level in real time, and prevent them from going outside the safe operation limits.

EMUS, UAB has developed the EMUS G1 BMS precisely for that purpose. It is a highly flexible, state of the art digital battery management system with a unique set of features and utility functions, that is designed to make the use of rechargeable lithium batteries straightforward and virtually maintenance-free, regardless of the battery size, capacity, voltage, and other factors.

This document covers all aspects of using the EMUS G1 BMS, and aims to provide the user with an in-depth knowledge about its core functionality and utility functions, as well as with information about its proper installation and configuration together with connection diagrams, examples, and recommendations - all in order to help to utilize all of its capabilities and prevent most commonly faced issues.

NOTE! Using EMUS G1 BMS requires at least basic knowledge in electronics and electrical engineering. The use of EMUS G1 BMS in any way other than it is intended, especially if that compromises its core functions, including modification of its components, is considered improper and will void any warranty. EMUS, UAB will not be held responsible for damage to the battery or any other consequences in case EMUS G1 BMS is used improperly, and reserves the right to not provide any technical support in such case.

3 Basics

EMUS G1 BMS is a digital, distributed topology battery management system that consists of a main controller, several cell controller boards (one for each individual cell), cell communication adapters, a current sensor, and few other optional components that all serve different purposes. The following subsections "System structure overview" and "Functionality overview" respectively outline the role of each of these components, and describe how they function and interact with each other in order to execute the core and utility functions of the battery management system.

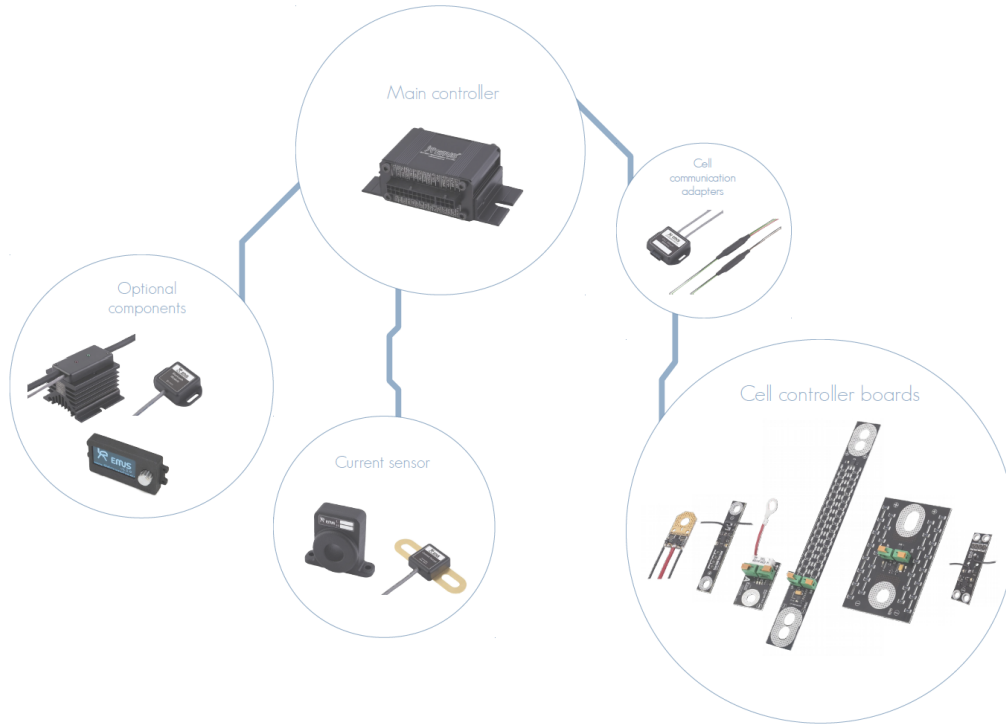

Figure 3.1: EMUS G1 BMS System

3.1 System structure overview

3.1.1 Control Unit

EMUS G1 Control Unit (or simply Control Unit) is the main controller that autonomously executes all core and utility functions of battery management. It interacts with all other first-party and third-party components in the system using various inputs, outputs and interfaces that are populated on its main 22 pin and secondary 8 pin connectors.

Depending on their purpose, all Control Unit pins can be divided into two categories: fixed and remappable. Fixed pins that dedicated for digital communication interfaces and power supply, and their position on the connector is permanent. Remappable pins are quite the opposite - they can be mapped with various different functions during configuration, meaning the default function of one pin can be remapped onto another pin. They are also further divided into general purpose and special purpose categories. A general purpose pin has a standard set of mappable functions, while a special purpose pin can also be mapped with certain function that is unique to that pin and cannot be mapped on others. Each of these pins is marked with its default function on the enclosure of the Control Unit.



Figure 3.2: EMUS G1 Control Unit

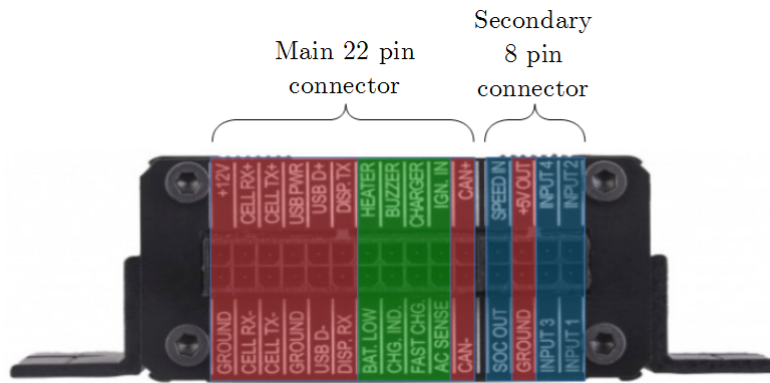

Figure 3.3: Control Unit's pins - fixed in red, general purpose remappable in green, and special purpose remappable in blue

3.1.1.1 Power supply inputs

Depending on the compatible power supply voltage, the Control Unit comes as either a 12V or a 24V controller. Accordingly, the “+12V” or “+24V” and “GROUND” pins at the top of the 22 pin connector are used for connecting the Control Unit to a power supply.

3.1.1.2 Data interfaces

3.1.1.2.1 USB

The Control Unit has a USB interface that is intended for quick and straightforward connection to a host device (e.g. computer, tablet, smartphone) when configuration, diagnostics, or maintenance is needed. It is populated on the main 22 pin connector as the “USBPWR”, “GROUND”, “USB D-”, and “USB D+” pins.

Although aimed for connecting to first-party applications on the host device, the USB interface can also be used with custom third-party applications developed by the users. Its is based on a USB to serial converter chip from FTDI, and the required USB drivers are royalty-free. The protocol that defines the format of the data exchanged between the Control Unit and the host application is described in an openly available document called [EMUS G1 Control Unit Serial Protocol](#).

3.1.1.2.2 RS232

The protocol used for data exchange over the Control Unit's RS232 interface is the same as the one used in data exchange over the USB interface, thus both of these interfaces are functionally identical. However, RS232 is inherently more robust than USB and is therefore more suitable for continuous BMS activity monitoring – either directly by a third-party controller, or by using the optional first-party EMUS G1 BMS components that are dedicated for this purpose. The RS232 interface is populated as the “DISP. RX”, “DISP.TX” and “GROUND” pins on the main 22 pin connector of the Control Unit.

3.1.1.2.3 CAN

Because of its popularity in automotive, industrial, and many other applications, EMUS G1 Control Unit is also equipped with a non-isolated CAN 2.0A/B interface. It is populated as the “CAN+”, “CAN-”, and “GROUND” pins on the main 22 pin connector. This interface is multipurpose, and enables the Control Unit to:

- Communicate with other CAN-equipped EMUS G1 BMS components;

- Control certain third-party charging devices;
- Transmit BMS activity data (either periodically or by request);
- Receive new configuration parameter values and other special messages;

The message format of the latter two follows a special proprietary CAN protocol that is described in a separate document called [EMUS G1 Control Unit CAN Protocol](#).

3.1.1.2.4 Serial cell communication interface

The serial cell communication interface is dedicated for connecting a certain type of cell communication adapters, and enables the Control Unit to communicate with the individual cell controller boards. It consists of “CELL RX-”, “CELL RX+”, “CELL TX-”, and “CELL TX+” pins on the main 22 pin connector.

3.1.1.3 General purpose inputs and outputs

Pins that fall into the general purpose output category are populated on the main 22 pin connector as the following:

- BAT.LOW;
- HEATER;
- CHG.IND;
- BUZZER;
- CHARGER.

They all share identical internal circuitry, and depending on the mapped function, are intended for driving relays, indicators, etc., or transmitting logic signals to various third-party devices.

Likewise, pins that fall into the general purpose input category are populated on the same connector as the following:

- FAST CHG.;
- AC SENCE;
- IGN.IN.

They are used by the Control Unit to read various logic signals from third-party devices.

As mentioned already at the beginning of this subsection, general purpose inputs and outputs are remappable, and are named after their default function.

3.1.1.4 Current sensor inputs

“INPUT1”, “INPUT2”, “INPUT3”, and “INPUT4” pins on the secondary 8 pin connector are special purpose analog input pins that are by default intended for interfacing the Control Unit with a current sensor. Nevertheless, they are remappable and can also work as digital inputs in case the current sensor is not used and current is monitored by external means. The adjacent “+5V OUT” and “GROUND” pins are intended for supplying power the current sensor when it is connected to the Control Unit.

3.1.1.5 SOC output

The "SOC OUT" pin on the secondary 8 pin connector is a special purpose digital output pin that can generate a 0-5V pulse-width-modulated signal. Depending on which of the two special function this pin is mapped with, such signal can be used for:

- Driving an analog fuel gauge - in such case the duty cycle of the generated PWM signal is directly proportional to the estimated battery state of charge;
- Controlling the output current of a certain type of charging devices - in this case the duty cycle of the PWM signal is proportional to the charging current requested by the Control Unit.

Apart from these two special functions, this pin can also be mapped any other standard output function and generate a corresponding logic signal.

3.1.1.6 Speed sensor input

The "SPEED IN" pin on the secondary 8 pin connector is a special purpose digital input that is wired directly to a peripheral that can measure frequency of a pulsed signal. By default it used used to measure the speed of an electric vehicle. The internal circuitry of this pin is almost identical to that of the general purpose inputs, therefore it can be mapped with any other digital input pin function if necessary.

3.1.2 Cell Modules

EMUS G1 Cell Module (or simply Cell Module) is a specially designed controller board that mounts directly on the terminals of a single cell, and serves the purpose of a voltage probe and a balancing device. It is equipped with:

- A cell voltage measurement circuitry;
- A shunt resistor based, passive balancing sub-circuit with a red indication LED;
- An internal temperature sensor;
- A special serial communication interface with green indication LED, that allows to connect the Cell Modules into a daisy chain network using a single wire between every two adjacent Cell Modules.



Figure 3.4: A standard A/B model Cell Module

Several models of the Cell Module are available, each of which is designed for cells with different capacity range or form factor. All of them are functionally identical, however some newer models also have an additional external temperature sensor for measuring the temperature of the cell during operation.

3.1.3 Cell Communication Adapters

Cell Communication Adapters are the gateway devices that provide galvanically isolated means of communication between the Control Unit and Cell Modules, thus eliminating the many safety and operation stability issues that would arise otherwise. There are two types of Cell Communication Adapters: Top and Bottom Isolators, and CAN Cell Group Modules.

3.1.3.1 Top and Bottom Isolators

EMUS G1 Top and Bottom Isolators are a specially designed pair of optical isolators that allow direct serial communication between the Control Unit and the Cell Modules. Such communication method is straightforward and low-cost, which makes it ideally suitable for relatively small (in number of cells), one-piece battery packs of series-connected cells. However, this cell communication adapter type has several weaknesses when used in a large battery pack, especially if it is physically split into several sub-packs. The large cumulative wire length of the whole cell communication daisy chain and the long individual communication wires between two adjacent Cell Modules compromise the integrity of the communication channel by making it more susceptible to electromagnetic noises. Also, because of the way the data is transferred in a daisy chain network, the energy consumption of each Cell Module, and consequently the self-discharge rate of each cell, is different. The more Cell Modules there are in a single chain, the more that difference is evident, which can be undesirable in systems that idle for a long period of time. It is therefore not recommended to use Top and Bottom Isolators in such cases.



Figure 3.5: Top and Bottom Isolators

3.1.3.2 CAN Cell Group Modules

EMUS G1 CAN Cell Group Modules (also known as CGMs) are advanced, microprocessor equipped cell communication adapters that allow the Control Unit to communicate with the Cell Modules over the CAN bus instead of directly. More than one of them can be used in a single battery pack, which allows to connect the Cell Modules into several small daisy chains instead of one long chain. This not only eliminates the drawbacks of the Top and Bottom Isolators, but also makes the EMUS G1 BMS capable to serve a virtually unlimited number of cells. Furthermore, it enables the EMUS G1 BMS to manage battery packs that consist of several strings of cells connected in parallel.



Figure 3.6: CAN Cell Group Module

3.1.4 Current Sensor

EMUS G1 Dual Range Current Sensor is an analog, hall-effect based current measurement device, specifically designed to be used as a part of EMUS G1 battery management system. It has two separate measurement channels with different sensitivity, which allows it to accurately measure small currents without sacrificing the range of measurable values. The hall-effect measurement method also provides an inherent galvanic isolation between sensor and the conducting part. There are two functionally identical types of the EMUS G1 Dual Range Current Sensor: the Bus Bar type, and the Closed Loop type.

3.1.4.1 Bus Bar Type

The first generation, or the Bus Bar type of EMUS G1 Dual Range Current Sensor is designed specifically for use in battery packs that consists of prismatic form factor cells. It doubles as an interconnecting bus bar, and due to the galvanic isolation between the sensor and the conducting part, it can be installed anywhere in the battery pack between two adjacent, series-connected cells.

3.1.4.2 Closed Loop Type

The second generation, or the Closed Loop type of EMUS G1 Dual Range Current Sensor has an improved design that makes it more rugged, accurate, and less sensitive to the environment factors when compared to the Bus Bar type. It also allows to install the sensor directly around a power cable without exposing any conducting parts, which makes it more adaptable and does not bind it to a particular cell form factor.



Figure 3.7: EMUS G1 Dual Range Current Sensor: (a) Bus Bar type; (b) Closed Loop type.

3.1.5 Solid State Relay (obsolete product)

NOTE: EMUS G1 Solid State Relay is obsolete product and is no longer manufactured. Information is included for referre EMUS G1 Solid State Relay is an electronic, solid state switching device that is designed specifically for toggling the AC power supply to any basic charging device, of which the output current cannot be controlled by other means. It enables EMUS G1 Control Unit to turn such device on and off in order to control the charging process. The Solid State Relay also has an "AC sense" feature, which allows the Control Unit to detect when the relay is connected to an AC power source and automatically start the charging process. A pair of LEDs on its enclosure provide a visual indication of the AC connection status and the relay's output state.



Figure 3.8: EMUS G1 Solid State Relay

3.1.6 Smartphone Connectivity Module

EMUS G1 Smartphone Connectivity Module is a wireless communication adapter that connects to the Control Unit via the RS232 interface, and enables external devices to connect to EMUS G1 Control Unit via BT protocol for monitoring, configuration, diagnostics, etc.



Figure 3.9: EMUS G1 Smartphone Connectivity Module

3.1.7 Display Unit

EMUS G1 Display Unit is a device dedicated to monitor battery status and other EMUS G1 Control Unit activity data in real time. It is designed for use outdoors having glare-free, high contrast and wide viewing angle display and control knob for accessing various information. Device has RS232 and USB interfaces for connection to Control Unit and Windows OS based PC respectively.



Figure 3.10: EMUS G1 Display Unit

3.1.8 Software

3.1.8.1 EVGUI Android and iOS applications



Figure 3.11: EMUS EVGUI Application

EMUS EVGUI (Electric Vehicle Graphical User Interface) is a freely available application for Android and iOS devices, designed specifically for monitoring the battery status in an electric vehicle. Using this application, a smartphone or a tablet can be connected to the Control Unit either via wireless BT protocol (using the EMUS G1 Smartphone Connectivity Module) or USB (using a USB-OTG cable, for Android devices only), eliminating the need for a dedicated display.

In its two main views EMUS EVGUI displays the most relevant statuses, such as vehicle speed, state of charge, estimated remaining distance, power consumption, etc. More detailed diagnostic information can be found in separate menus. The application can also log BMS activity data into a file for further analysis by a technical support specialist when necessary.



Get it on Google Play



Download on Apple App Store

Figure 3.12: Download the app for Smartphone

3.1.8.2 Control Panel

EMUS G1 Control Panel (or simply Control Panel) is the official Windows PC software tool for configuration, maintenance, and diagnostics of the EMUS G1 BMS. It comprehensively displays all BMS activity data received from the Control Unit, gives quick and effortless access to each individual configuration parameter, and allows to easily and safely perform virtually all maintenance operations. The Control Panel supports multiple languages, and is freely available online at <https://emusbms.com/support>.

3.2 Functionality overview

3.2.1 Cell Monitoring

Individual cell monitoring is a fundamental and one of the most important functions of EMUS G1 BMS. It is a complex, multi-part process in which certain roles are distributed between Cell Modules and the Control Unit.

Each Cell Module, once mounted on a cell, starts its work routine during which it measures the cell's voltage and its own temperature (as well as the external temperature, if applicable), and uses the measured values to regulate the balancing current in an attempt to keep the cell's voltage lower than the balancing threshold, while at the same time keeping its own temperature lower than a certain maximum value to protect itself from overheating.

The Control Unit retrieves the measured voltage and temperature values, as well as the balancing rate value (which is the duty cycle of the PWM signal that is used for controlling the balancing current) from the Cell Modules by means of "request-response" type communication with them. When using the Top and Bottom Isolators, it all begins when the Control Unit sends out a particular request command over the Serial Cell Communication Interface. Each Cell Module exploits the difference in electric potential between adjacent cells by echoing any logic state change at the "Dn" input to the "Up" output, therefore the request command is transferred throughout the whole daisy chain network of Cell Modules. Because the echo delay is almost negligible, all Cell Modules in the network receive the command nearly simultaneously. Once the command is received, each of them save the most recent measured value of the requested parameter and then take turns to send it to the Control Unit by forwarding the data through subsequent Cell Modules in the chain (as illustrated in Figure 3.13a). The robustness of such transfer process is ensured by additional forward error correction data that the sender attaches to each sent byte, which allows the Control Unit to detect and correct certain errors. The cell communication procedure is complete when the Control Unit has received responses from all of the cell modules.

When using CAN Cell Group Modules, the Control Unit sends out the request message over the CAN interface instead of the Serial Cell Communication Interface. Because of the specific properties

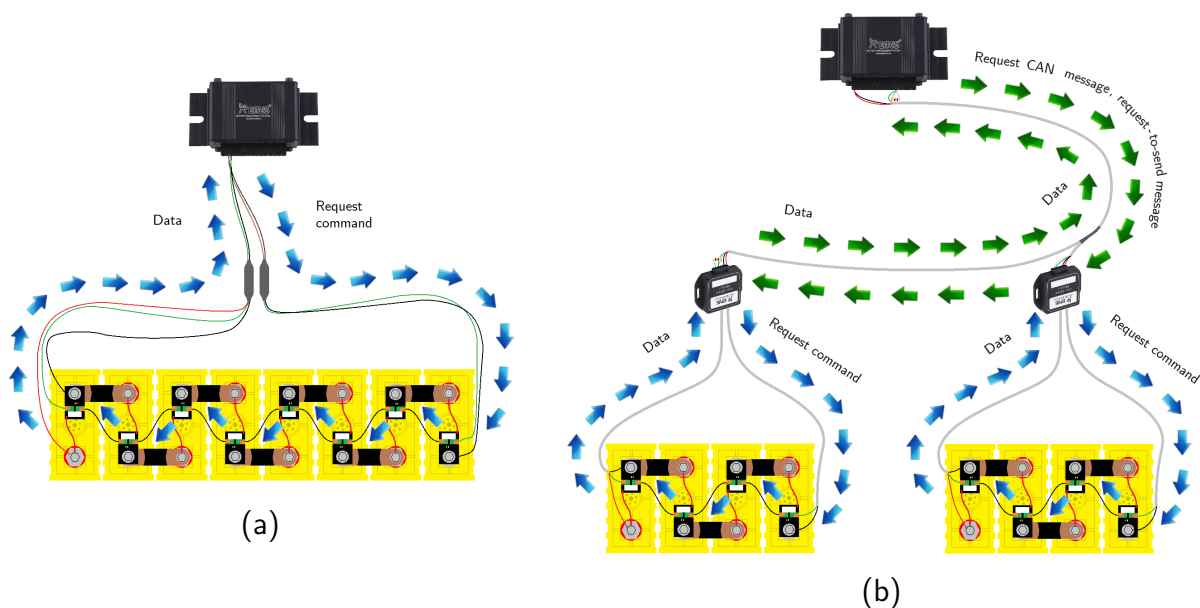

Figure 3.13: Cell communication data flow: (a) when using Top and Bottom Isolators; (b) when using CAN Cell Group Modules.

of CAN communication all CGMs on the CAN bus receive the request message simultaneously, and from here the cell communication process is very similar to when the Control Unit is communicating

with the Cell Modules via the Top and Bottom Isolators. Each CGM send out a request command over the special serial interface to its own daisy chain network of cell modules, and stores the data received in response. The Control Unit then retrieves the data from each CGM successively by sending a special request-to-send message to it (as illustrated in Figure 3.13b).

The Control Unit periodically performs the cell communication procedures described above in order to ensure that the cell parameter values that are stored in its memory are always up-to-date and valid. Normally, each period the Control Unit requests a different cell parameter according to a prioritizing scheme: highest priority is given to the cell voltages, meaning that they are requested more often than other parameters, the balancing rates come second, and both the external and internal cell module temperatures have the lowest priority. However, if an attempt to acquire any particular cell parameter results in an error or a timeout, that cell parameter is considered no longer valid and the prioritizing scheme is ignored by giving exclusive priority to acquiring it in the next period. Cell parameter monitoring period depends on the number of cells in the battery pack, and is most of time equal to

$$10 + \frac{\text{"Total Number of Cells"}}{5} \quad (1)$$

milliseconds (where "Total Number of Cells" is the value of a corresponding configuration parameter), but is gradually increased to up to 5 seconds if the system is idling, (i.e. charger is disconnected, ignition input is in a low state, measured current is equal to zero, and all cell parameter values are valid).

All core EMUS G1 Control Unit functions only use the minimum, maximum, or average values rather than individual cell data, therefore only these aggregated values are normally stored during the periodic cell monitoring process. However, the individual cell data may still be useful for diagnostic purposes, therefore it can be acquired by request over USB, RS232, or CAN interfaces. Such requests are registered in a queue, and are serviced during the periodic cell monitoring by temporarily saving the individual cell data of the requested parameter in a special buffer. The saved data is then sent out in chunks over the same interface from which the request came. It is also important to notice that the previously mentioned prioritizing scheme that is used during periodic monitoring is bypassed in order to acquire the data that is needed to service the active individual cell data request. To compensate this, the parameter monitoring period is temporarily decreased to a minimum value in such case.

3.2.2 Current measurement

The measurement of the battery current in EMUS G1 BMS comprises of two continuous, simultaneously executed processes. During the first process, the Control Unit continuously measures the analog signals given by EMUS G1 Current Sensor using a high sample rate analog-to-digital converter peripheral, and periodically stores averaged measurement results for further processing. The averaging is needed in order to mitigate the effects of thermal, quantization and other noises.

During the second process, the most recent results of the measurement process are taken, verified for validity, and used for calculating the momentary battery current value by subtracting the "Zero Offset" parameter value and multiplying by either "L Calibration Value" or "H Calibration Value" parameter value depending on the magnitude of the raw measured value. Before storing the result for use in higher level algorithms, the momentary current value is further processed by applying the "Dead zone" and "Reverse Direction" configuration parameters. This process runs at a steady rate of 100Hz.

3.2.3 SOC estimation

State of Charge estimation in EMUS G1 BMS is mainly based on the coulomb counting technique, with few exceptions where the SOC value is adjusted by cell voltage in order to mitigate its drawbacks.

The coulomb counting is done in sync with the current update process: every newly determined momentary current value is multiplied by the update period, and the result, regardless of its sign, is accumulated into volatile memory as Battery Charge value (in Ah). This value is later compared to "Capacity" configuration parameter value in order to determine the SoC expressed in percentage.

The Battery Charge value belongs to a group of special non-volatile status values that are normally stored in volatile memory due to their inclination to change frequently, but are periodically backed up into Control Unit's non-volatile memory in order to retain them even after the power supply to EMUS G1 Control Unit has been cut off. The Control Unit's non-volatile memory consists of separate EEPROM and non-volatile RAM type memories, and the mentioned values are stored in both of them so that the drawbacks of each memory type would be eliminated. The EEPROM type memory can retain the data practically indefinitely after its supply power is cut off, however it can withstand only a limited number of write cycles, therefore the mentioned values are backed up to it only each hour or sixteen minutes, depending on whether the BMS is in passive or active state. In this case the BMS state is considered to be active as long as a charger is connected or on active signal is detected on any general purpose input pin mapped with "PF4 Ignition Key Input" pin function. Non-volatile RAM memory is not guaranteed to retain the data if BMS power supply is cut off for an extended period of time, however it does not have any write cycle limitations, therefore the non-volatile statuses are backed up to it every second regardless of the BMS state.

3.2.3.1 Adjustment by cell voltage

Because the coulomb counting method suffers from long-term drift due to even slight inaccuracies of the current measurement, the SOC is adjusted to 100% each time the charging process successfully finishes by equating the battery charge to the value of "Capacity" configuration parameter. If such adjustment is insufficient in a particular application (e.g. solar energy storage, where the charging process may not finish for many consecutive days if there is not enough sunlight), the optional "Reduce SOC at Under-Voltage" feature maybe used. When its enabled, the battery charge value is adjusted in such way that the SOC would match the "SOC at Low Volt. Warn." parameter or 0% respectively whenever the Low Cell Voltage reduction or Cell Under-Voltage protection is activated. In both cases, the following conditions also need to be met for the adjustment to take place:

- The battery current has to stay below 0.5C for at least 5 seconds;
- The currently estimated SOC value has to be greater than that which would be after the adjustment.

Once the adjustment of a particular type takes place, it will only be repeated if the corresponding reduction or protection is cleared, and the SOC value becomes greater than the corresponding adjustment value before the adjustment condition is met again.

3.2.4 Charging process and charging device control

EMUS G1 Control Unit controls the charging process and regulates the output current of the charging device according to the feedback of various measured battery parameters. This ensures that the battery is charged safely and the cell voltages are correctly balanced after the charging process is finished, and is one of the most important functions of EMUS G1 BMS. Various third-party charging devices are supported for that purpose, which can be categorized into three distinct types based on how they are controlled:

1. Basic charging devices that do not have any EMUS G1 Control Unit compatible interface for controlling their output current and voltage (also referred to as non-CAN charging devices) are controlled by utilizing a special algorithm to turn them on an off using a switching device that is driven by a general purpose output pin mapped with "PF10 Charger Enable Output" pin

function. The Control Unit acknowledges the connection and disconnection of such charging device whenever a corresponding high/low signal is detected on a general purpose input pin mapped with "PF3 Charger Mains AC Sense Input" function;

2. Charging devices that are equipped with a CAN interface (or simply CAN chargers) are controlled by sending the requested output voltage and current values to them in a CAN message using a protocol that is specific to a particular charger. In this case the "PF10 Charger Enable Output" pin function is used only for disconnecting the charger from the battery in case of a critical condition, and should drive a corresponding contactor that is separate from the main contactor. Currently EMUS G1 Control Unit officially supports the following CAN chargers:
 - J1939 protocol compatible chargers(TC, Elcon HF/PFC or IEB chargers with CAN interface);
 - Eltek Valere EV Power Chargers;
 - Zivan NG and SG series chargers with CAN interface;
 - Powerfinn Robust and PAP3200 chargers with CAN interface.
 - Delta-Q

Up to 16 identical CAN chargers connected in parallel can be controlled by EMUS G1 BMS if each individual charger is set up to use a unique CAN identifier. The Control Unit detects each charger automatically and relies on the "Number of Chargers" parameter in order to correctly distribute the charging current among all connected chargers. This means it expects that the number of connected chargers will be equal to or less than this parameter, and determines the output current of each connected charger using the following formula:

$$I_n = \frac{I_{Requested}}{\text{"Number of Chargers"}} \quad (2)$$

where $I_{Requested}$ is the requested charging current, and "Number of Chargers" is the value of the corresponding parameter. Naturally, the charging will be stopped if the number of connected chargers exceed the "Number of Charger" parameter value to avoid overloading the chargers.

The Control Unit acknowledges that a CAN charger is connected when it receives a particular CAN message from at least one charger. Depending on the charger model, the charger transmits this message either by itself (periodically), or as a response to a request CAN message from the Control Unit. Disconnection is acknowledged if the Control Unit does not receive any CAN message from the charger(s) for more than 15 seconds. Consequently, the "PF3 Charger Mains AC Sense Input" pin function has no meaning when using this type of charging device.

3. Charging devices of which the output current is proportional to the control signal voltage level (also referred to as analog signal controlled chargers) are controlled by a corresponding PWM signal generated on the "SOC OUT" pin of the Control Unit, which has to be mapped with "PF18 Analog Charger Control Output" pin function for that matter. The resultant minimum and maximum voltage levels of such signal can be adjusted in between 0V to 5V range by changing the values of the corresponding "Min PWM Output" and "Max PWM Output" parameters in order to match the requirements of the charging device.

The role of the "PF10 Charger Enable Output" pin function when using an analog signal controlled charger is identical to when a CAN charger is used, while the connection and disconnection is acknowledged the same way as for the non-CAN charging devices.

It is important to note that due to Control Unit's internal memory limitations EMUS G1 Control Unit can support only one charging device type or model at a time, and it is necessary to re-upload the Control Unit with a different firmware in case it is desired to change the supported type or model.

Regardless of the charging device type, the charging process begins when the Control Unit detects that a charging device has been connected. EMUS G1 Control Unit divides it into six separate stages:

1. **"Pre-Heating" stage** is entered when the minimum cell module temperature (or minimum cell temperature if both are available, whichever of them is lower), which is assumed to equal to the ambient temperature of the battery pack, is lower than the threshold set by "Minimum Charging Temperature" parameter (1°C by default). This points that the battery is too cold to be charged safely, therefore during this stage the Control Unit attempts to warm it up by activating the general purpose output pin that is mapped with "PF5 Heater Enable Output" function. This function is intended for switching a third-party heating device (a heater) on and off. The charging device is disconnected from the battery using the general purpose pin mapped with "PF10 Charger Enable Output" pin function in the meantime.
2. **"Pre-Charging" stage** is entered when the minimum cell voltage is lower than "Pre-charge Threshold" parameter value. It is assumed that the cell are deeply discharged if this condition is met, therefore during this stage the battery is charged with a reduced current in order to avoid heat development inside the cells due to their increased internal resistance.

The actual charging current during this stage depends on the charging device type and several configuration parameters:

- When using a CAN charger, the charging current during this stage is determined according to the following formula:

$$I_{Charging} = \frac{Capacity \cdot 100}{Pre\text{-}charge\ Current} \quad (3)$$

where "Capacity" and "Pre-charge Current" are the values of corresponding configuration parameters;

- When using an analog signal controlled charging device, the charging current does not depend on the "Capacity" parameter, and is instead determined according to the following formula:

$$I_{Charging} = \frac{I_{Max} \cdot 100}{Pre\text{-}charge\ Current} \quad (4)$$

where I_{Max} is the current that charger outputs when the control signal is at its maximum value (which is determined by the "Max PWM Output" parameter), and "Pre-charge Current" is the value of the corresponding configuration parameter;

- When using a non-CAN charging device, the "Pre-Charging stage" is skipped because EMUS G1 Control Unit does not have the ability to effectively reduce its output current without potentially forcing it to function outside of its normal operating conditions.
3. **"Main Charging" stage** is entered if the maximum cell voltage is less than "Fully Charged Voltage" parameter value and no condition to enter any other stage is present, which indicates that no special precautions are needed in order to charge safely, therefore during this stage the battery is charged with the highest possible current. The actual charging current value depends on certain EMUS G1 Control Unit configuration parameters as well as the physical limitations of the used charging device:

- When using a CAN charger, the charging current during this stage is set by either the "Fast Charging Current" or "Slow Charging Current" parameter value depending on the state of the general purpose input pin that is mapped with "PF2 Fast Charge Switch Input" pin function. If this function is not mapped "Slow Charging Current" parameter is used by default;
- When using an analog signal controlled charging device, the charging current during this stage is equal to the charging device's output current value to which the control signal corresponds when it is equal to "Max PWM Output" parameter value;
- When using a non-CAN charging device, the charging current during this stage depends solely on its maximum output current.

During this stage EMUS G1 Control Unit also executes the early balancing algorithm. This means that if the maximum cell voltage is higher than "Early Balancing Threshold" parameter value, and the difference between minimum and maximum cell voltages is more than "Allowed Disbalance" parameter value, the balancing threshold is set to minimum cell voltage plus 5mV, but not higher than maximum cell voltage. In result, balancing is enforced on the cells with the highest voltages, which can effectively shorten the duration of the charging process if the battery pack is significantly disbalanced (for example when being charged for the first time after installation).

4. **"Balancing" stage** is entered when the maximum cell voltage is more than or equal to the "Fully Charged Voltage" parameter value. At this point, the difference in stored energy between the cells is proportional to the difference in their voltages, therefore during this stage EMUS G1 Control Unit takes several actions to eliminate that difference and balance them. Firstly, the balancing threshold is by default equal to "Fully Charged Voltage" parameter value as well, therefore the corresponding Cell Module(s) naturally start to divert the charging current through their shunt resistors in attempt to prevent the cell voltages from rising further. Secondly, the charging current is also controlled respect in to similar criteria, however this process differs depending on what type of charging device is used.

When using a CAN or analog signal controlled charger, the charging current during this stage is precisely regulated in such way that the voltages of already fully charged cells would not rise much further, but at the same time it would not be equal to zero so the cell that are not full yet could "catch up". The "Balancing stage" is over if at the moment when the charging current drops below "Charging Finished Current" parameter value the max cell voltage is equal to "Fully Charged Voltage" parameter value, the difference between minimum and maximum cell voltages is less than the value of "Allowed Disbalance" parameter, and minimum balancing rate is more than a half of maximum balancing rate.

When using a non-CAN charging device EMUS G1 Control Unit does not have any means to regulate the charging current, therefore in such case this stage is a bit different. When it begins, the charging device is kept on until the maximum cell voltage starts to exceed the "Fully Charged Voltage" parameter value by more than 20mV, even though the corresponding cell module is shunting the charging current. Then the charging device is turned off and the balancing threshold is set to minimum cell voltage plus the value of "Allowed Disbalance" parameter (but not higher than "Fully Charged Voltage" parameter value) in order to dissipate the energy difference between cells as heat. This continues until the maximum balancing rate drops to 5% or lower, but not for shorter than 10 seconds. If at the end of this phase the difference between minimum and maximum cell voltages is lower than the "Allowed Disbalance" parameter value, this stage is over, otherwise the charging device is turned on again and this process repeats.

5. **"Charging Finished" stage** is entered whenever the "Balancing stage" is completed. This indicates that the charging process is complete, therefore during this stage the charging device, regardless of its type, is disconnected from the battery by deactivating the general purpose output pin mapped with "PF10 Charger Enable Output" pin function.
6. **"Charging Error" stage** is entered if one of several pre-defined critical conditions are met during the charging process. During this stage, the Control unit attempts to protect the battery by deactivating the general purpose output pins mapped with "PF10 Charger Enable Output" and "PF5 Heater Enable Output" functions in order to disconnect it from both the charging device and the heater. Conditions that result in transition to "Charging Error stage" are the following:
 - No cell communication – if cell communication is lost during any stage of the charging process, EMUS G1 Control Unit will terminate the charging since it cannot determine the cell parameters in such case. However, if this condition is already active at the beginning of the charging process and "Cell Comm Restore" feature is enabled, EMUS G1 Control Unit will not register a charging error for as long as the "Restore Duration" parameter value. During this time, EMUS G1 Control Unit will go into "Pre-Charging stage" if CAN or analog signal controlled charger is used, or into "Main Charging stage" in case a non-CAN charging device is used. This way it will attempt to restore the cell communication by charging the cells, assuming that it is not present because they are discharged too deeply and their voltages are insufficient to power the Cell Modules;
 - Charging stage duration exceeded – if the duration of either "Pre-Charging stage", "Main Charging stage", or "Balancing stage" has exceeded the value of corresponding Max Pre-Charging Stage Duration, Max Main Charging Stage Duration, or Max Balancing Stage Duration parameter, the charging is terminated as this may indicate a bad cell, big energy leak, or simply not optimal EMUS G1 BMS configuration;
 - Detected number of cells do not match "Number of Overall cells parameter – if the number of detected cells does not match "Number of Overall Cells parameter the charging is terminated, since this indicates either a cell module malfunction, or that EMUS G1 Control Unit is configured incorrectly;
 - Protection event occurred – if either the Charge Over-Current, Discharge Over-Current, Insulation Fault, or No Current Sensor protection is enabled and active, the charging is terminated. Conditions to enter this stage that are equivalent to other protections (except Cell Under-Voltage, Charger Connected, and Pack Under-Voltage protections) are considered to be the most critical and are checked separately in order to eliminate the possibility to turn off their checking by disabling the corresponding protection. Conditions equivalent to Cell Under-Voltage, Charger Connected, and Pack Under-Voltage protections are not checked in order to avoid blocking the charging process;
 - Cell or cell module temperature too high – EMUS G1 Control Unit will terminate the charging if internal cell module temperature is higher than the value of Cell Module Over-heat protection "Activate at" parameter, or external cell module temperature is higher than the value of equivalent Cell Over-Heat protection parameter, since this indicates that the ambient temperature is too high or that there is an unexpected heat development somewhere in the battery;
 - Cell Over-voltage – EMUS G1 Control Unit BMS will terminate the charging if maximum cell voltage rises above the threshold set by Cell Over-voltage protection "Activate at" parameter, as this indicates that either a charging device malfunction, or incorrect BMS configuration.

Each charging stage continues until the entering condition is no longer active, except for the "Balancing stage" case, which is already described above. Another exception is the "Charger Error stage" when it is entered due to "Charging stage duration exceeded" condition being active - in this case it is possible to clear the entering condition only by manually disconnecting and reconnecting the charging device.

The order in which the charging stages are executed is not strictly defined, and although some of the stages tend to naturally go one after another in the same order as they are listed above, it varies depending on the situation. However, there are several hard-coded rules and exceptions that affect it:

- The occurrence of entering conditions of the "Pre-heating stage" and "Charging Error stage" is not directly related to the battery state of charge and is abrupt by nature, therefore these stages can take place at any point in the charging process and interrupt any other stage;
- Once the "Balancing stage" has been entered, EMUS G1 Control Unit will not go back to "Main Charging stage" directly;
- Once "Charging Finished stage" has been reached, EMUS G1 Control Unit will go not back to "Pre-Charging stage", "Main Charging stage", or "Balancing stage" directly unless the maximum cell voltage has dropped below "Charger Restart Voltage" parameter value. This also applies if "Charging Finished stage" is interrupted by "Pre-heating stage" or "Charging Error stage".

The charging process is over when the Control Unit acknowledges that the charging device has been disconnected regardless in which charging stage EMUS G1 Control Unit is at the time, and is not resumed but started over if the charging device is reconnected.

It is important to note that for safety reasons the Control Unit does not allow to change any configuration parameters during the charging process, except during "Charging Error stage", or if the parameter in question is the "Invert" option of the general purpose input pin that is mapped with "PF3 Charger Mains AC Sense Input" pin function, but only if a non-CAN or analog signal controlled charger is used.

3.2.4.1 Charging Interlock

When one of the Control Unit's general purpose output pins is mapped with "PF17 Charging Interlock" pin function, it generates a dedicated control signal that is active as long as the charging device is connected, regardless of any other condition. This feature is useful if during charging it is necessary to disable some equipment in the system (for example the motor controller) without disconnecting the main contactor, and works with any type of charging device.

3.2.5 Battery protections

During discharge, EMUS G1 BMS Control Unit protects the battery from operation beyond certain limits of its parameters (voltage, temperature, current) by deactivating the general purpose output pin mapped with "PF12 Battery Contactor Output" pin function. This pin function is intended for driving the main contactor that disconnects the battery from the load. There are eleven different protection types:

- Cell Under-Voltage protection prevents the battery from being discharged further if the voltage of at least one of the cells is below the threshold set by the corresponding "Activate at" parameter;

- Cell Over-Voltage protection prevent the cells from being overcharged during regenerative processes, and is activated if the voltage of at least one of the cells is above the threshold set by the corresponding "Activate at" parameter;
- Discharge Over-Current protection is activated if the measured discharge current is above the threshold set by the corresponding "Activate at" parameter, thus preventing the battery from being discharged at a rate that is higher than specified by the cell manufacturer;
- Charge Over-Current protection disconnects the main contactor if the measured charge current is above the threshold set by the corresponding "Activate at" parameter, thus preventing the high currents during regenerative processes from potentially damaging the cells;
- Cell Module Over-Heat protection prevents the battery from being operated when the temperature measured by the internal cell module's temperature sensor is above the threshold set by corresponding "Activate at" parameter, which is likely to be caused by sparking/bad contact, an equipment failure, or a bad cell;
- No Cell Communication protection prevents battery operation when EMUS G1 Control Unit is not able to monitor the cells due to a hardware malfunction or incorrect installation;
- Insulation Fault protection, which disconnects the battery from the load in case an active signal is detected on a general purpose input pin that is mapped with "PF15 Leakage Sensor Input" function. Such signal is meant to be generated by a third-party insulation fault detector that is selected appropriately for the application;
- Cell Over-Heat protection prevents the battery from being operated when the temperature measured by the external temperature sensor of one of the cell module is above threshold set by corresponding "Activate at" parameter, which may indicate an unexpected heat development somewhere in the battery;
- No Current Sensor protection prevents the battery from being operated if the Current Sensor is connected improperly or not connected at all;
- Charger Connected protection disconnects the main contactor if the charging process is taking place;
- Pack Under-Voltage protection prevents the battery from being discharged further if the voltage of the battery pack is below the threshold set by the corresponding "Activate at" parameter;

All ten protections are enabled by default, but can be disabled individually during configuration if necessary. Each protections that has an "Activate at" threshold parameter also has a separate "Deactivate at" threshold parameter that allows to create a hysteresis between activation and deactivation. Regardless of that, all protections except "Charger Connected" have configurable activation and deactivation delays. This means that EMUS G1 Control Unit will tolerate the activation condition for as long as the corresponding "Activation delay" parameter value before activating the protection. Likewise, the deactivation condition has to persist for as long as the corresponding "Deactivation delay" parameter value for the protection to be deactivated.

It is important to note that Cell Under-Voltage, Cell Over-Voltage, Cell Module Over-Heat, Cell Over-Heat and Pack Under-Voltage protections will be activated only if the corresponding cell parameter values are valid. Also, if the "No cell communication" protection is enabled, it will be active when the Control Unit is powered up by default, thus prevent the main contactor from closing until cell communication is established. Deactivation delay will have no effect in this case, and the protection will be deactivated immediately when cell communication is established.

3.2.5.1 Contactor pre-charge

In a lot of different applications the battery that is managed by EMUS G1 Control Unit connects to a load that has a substantial input capacitance. In such case, it is often desirable to limit the high in-rush current that occurs when the main contactor is closed in order to reduce stress to the internal components of the load device and prevent the contactor from welding. For that reason, EMUS G1 Control Unit offers a very straightforward contactor pre-charge feature (not to be confused with "Pre-Charging stage" that occurs during the charging process).

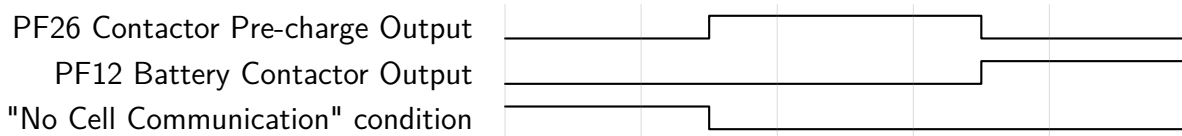

Figure 3.14: Contactor pre-charge timing diagram

This feature works by activating a general purpose output pin that is mapped with "PF26 Contactor Pre-Charge Output" pin function for a period of time that is equal to "Contacto Pre-charge Duration" parameter value whenever the main contactor needs to be closed, as shown in Figure 3.14 (i.e. during system power-up, or when a protection is deactivated). The mentioned pin function should drive a current limiting pre-charge sub-circuit that bypasses the contactor.

3.2.5.2 External contactor deactivation

In case it is desired to allow an external system that utilizes EMUS G1 Control Unit to override the control of the main contactor without compromising the contactor pre-charge functionality, the External Contactor Deactivation feature can be used. When it is enabled, the general purpose output pin mapped with "PF12 Battery Contactor Output" pin function remains deactivated unconditionally until the Control Unit receives a special activation message over the CAN interface. From that point the mentioned pin is controlled in a normal manner, and becomes unconditionally deactivated again only if Control Unit receives a special deactivation message over the CAN interface. Alternatively, if the "Reset External Contactor Deactivation On Protection" sub-feature is enabled, the main contactor remains open every time it is disconnected due to active protection, even if the protection condition is cleared. In such case it is necessary to send the special activation CAN message again. The detailed information about the activation and deactivation messages is out of the scope of this document, and can be found in the [EMUS G1 Control Unit CAN Protocol](#) document instead.

3.2.6 Power reductions

Apart from protecting the battery during discharge by disconnecting the main contactor, EMUS G1 Control Unit can also generate a separate "power reduction" signal on a general purpose pin if it is mapped with "PF16 Power Reduction Output" pin function. This signal can be used both for disconnecting non-essential loads or activating a power reduction mode on the load device (e.g. motor controller), and for a second level of protection that has a different reaction time, or simply for indication. There are four reduction types:

- Low Cell Voltage reduction is activated if the voltage of at least one of the cells is below the threshold set by the corresponding "Activate at" parameter;
- High Discharge Current reduction is activated if the measured discharge current is above the threshold set by the corresponding "Activate at" parameter;
- High Cell Module Temperature reduction is activated if the internal temperature of one of the cell modules is above the threshold set by corresponding "Activate at";

- High Cell Temperature reduction is activated when the temperature measured by the external temperature sensor of one of the cell module is above threshold set by corresponding "Activate at" parameter.

Similarly to the protections, each reduction also has a configurable deactivation threshold (if applicable), as well as configurable activation and deactivation delays. All four reductions are enabled by default, but can be disabled individually during configuration.

3.2.7 Heater and cooling fan control

In order to allow safe and reliable use of lithium batteries in various climate conditions, EMUS G1 Control Unit offers several different options to control a heater and/or a cooling device. Any of the Control Unit's general purpose output pins mapped with the "PF13 Battery Fan Output" pin function will be activated whenever either the maximum cell module temperature or maximum cell temperature (if both are available) is above the threshold set by "Fan On Temperature" parameter. Such output is intended to control a cooling device that is used for cooling the Cell Modules during the "Balancing stage" of the charging process, which allows to reduce the duration of this stage. Alternatively it can control a cooling device that is used for cooling the whole battery, and thus diminish the accelerated aging effect that operation in hot climate has on the battery, or protect the battery from overheating if it is discharged using very high current.

Most lithium chemistry batteries cannot be charged in temperatures below 0 °C without causing irreversible loss of capacity or even a short circuit between the electrodes due to the accumulation of metallic lithium on the anode that occurs in such conditions. For this reason EMUS G1 Control Unit attempts to "pre-heat" the battery before charging by activating any general purpose output pin mapped with "PF5 Heater Enable Output" pin function, which is intended for controlling a heating device. This feature is described in more detail in chapter [3.2.4](#).

3.2.7.1 Climate Control

In case it is desired to utilize a heating device for keeping the temperature of the battery at a certain level at all times instead of using it only for pre-heating the battery before charging, the "Climate Control" feature can be used. When it is enabled in the configuration, the general purpose pin mapped with "PF5 Heater Enable Output" function will be active as long as both the minimum cell module temperature and minimum cell temperature (if both are available) are not more than 1°C above the threshold set by either "Normal Temperature" or "Charging Temperature" parameter depending on whether charging is taking place or not. Once deactivated, it is activated again if either minimum cell module temperature or minimum cell temperature (if both are available) falls more than 1°C below the said threshold. Cooling device control feature mentioned in the parent chapter is completely separate from the Climate Control, and therefore these two features can be used both independently and in combination. Climate Control algorithm includes several safety mechanisms to prevent the battery from being drained in case the heating device is powered directly from it, meaning that the heating device is deactivated regardless of the temperature of the cells modules (or cells) in the following cases:

- If the estimated battery state of charge (SOC) is below "Minimum SOC" parameter value;
- If the minimum cell voltage is less than the value of "Activate at" threshold of Cell Under-Voltage protection;
- If charger is not connected for longer than the value of "Max duration when not charging" parameter.

It is also important to note that heating device control during the "Pre-Heating stage" of the charging process completely overrides Climate Control feature."

3.2.8 DC/DC converter control

In some applications where grid power is not available all the time (e.g. off-grid energy storage, electric vehicle, etc.), the main battery usually supplies power to an auxiliary 12 or 24V network through a DC/DC converter, which in turn also supplies power to EMUS G1 Control Unit. This means that if the DC/DC converter is not disconnected from the battery before leaving the system out of operation for an extended period of time, the BMS remains powered and can potentially drain the battery if its not charged during that time. EMUS G1 Control Unit has a special feature that allows to disconnect the DC/DC converter automatically in order to prevent such situations.

The DC/DC converter control feature is active by default, without the need to be enabled in the configuration, and deactivates any Control Unit's general purpose output pin that is mapped with "PF24 DC/DC Control Output" pin function if the minimum cell voltage becomes lower than or equal to the value of corresponding Active State Threshold or Passive State Threshold parameter. In this case the BMS state is considered to be active as long as a charger is connected or an active signal is detected on any general purpose input pin mapped with "PF4 Ignition Key Input" pin function, and the parameter to be used is determined accordingly. The mentioned output is intended for driving a relay/contactor that disconnects the DC/DC converter from the battery, and is activated again if the minimum cell voltage rises above the value of relevant threshold parameter by more than 10mV, but not sooner than 10 seconds after it was deactivated.

3.2.9 Statistics

"For diagnostic purposes, EMUS G1 Control Unit keeps track of various pre-defined battery and BMS operation statistics and stores them in its internal non-volatile memory. Each statistic, depending on its type, can consists of a corresponding main value, additional value, and a timestamp. A list of all statistics is provided in Table 3.1.

Table 3.1: List of statistics and their descriptions

ID	Statistic	Description
1	Total discharge*	The total amount of charge transferred out of the battery in Ah (or kAh if normal range has been overflowed).
2	Total charge*	The total amount of charge transferred into the battery in Ah (or kAh if normal range has been overflowed).
3	Total discharge energy*	The total amount of energy transferred out of the battery in Wh (or kWh if normal range has been overflowed).
4	Total charge energy*	The total amount of energy transferred into the battery in Wh (or kWh if normal range has been overflowed).
5	Total discharge time*	The total amount of time when negative (discharge) current was measured is seconds (or hours if normal range has been overflowed).
6	Total charge time*	The total amount of time when positive (charge) current was measured in seconds (or hours if normal range has been overflowed).
7	Total distance*	The number of speed signal pulses registered on SPEED IN input when it is mapped with "PF1 Speed Sensor Input" pin function.
8	Max Discharge Current	The highest recorded discharge current value. This statistic also contains the timestamp of when the value was recorded.
9	Max Charge Current	The highest recorded charge current value. This statistic also contains the timestamp of when the value was recorded.
10	Master clear count*	The number of times the master clear procedure has been performed.

11	Min Cell Voltage	The lowest recorded cell voltage. Additionally contains the cell number and timestamp of when this value was recorded.
12	Max Cell Voltage	The highest recorded cell voltage. Additionally contains the corresponding cell ID and timestamp of when this value was recorded.
13	Max Cell Voltage Difference	The highest recorded difference between cell voltages. Additionally contains the corresponding minimum and maximum cell voltages, ID of the cell with minimum voltage, and timestamp of when these value were recorded.
14	Min Pack Voltage	The lowest recorded battery pack voltage. Additionally contains timestamp of when this value was recorded.
15	Max Pack Voltage	The highest recorded battery pack voltage. Additionally contains timestamp of when this value was recorded.
16	Min cell module temperature	The lowest recorded cell module temperature. Additionally contains the corresponding cell ID and timestamp of when this value was recorded.
17	Max cell module temperature	The highest recorded cell module temperature. Additionally contains the corresponding cell ID and timestamp of when this value was recorded.
18	Max cell module temperature difference	The highest recorded difference between cell module temperatures. Additionally contains the corresponding minimum and maximum cell modules temperatures, ID of the cell module with minimum temperature, and timestamp of when these value were recorded.
19	BMS start count	The number of times EMUS G1 Control Unit has been powered up. Additionally contains the timestamp of the last occurrence.
20	Under-voltage protection count	The number of times Cell Under-Voltage protection has been activated. Additionally contains the timestamp of the last occurrence.
21	Over-voltage protection count	The number of times Cell Over-Voltage protection has been activated. Additionally contains the timestamp of the last occurrence.
22	Discharge over-current protection count	The number of times Discharge Over-Current protection has been activated. Additionally contains the timestamp of the last occurrence.
23	Charge over-current protection count	The number of times Charge Over-Current protection has been activated. Additionally contains the timestamp of the last occurrence.
24	Cell module overheat protection count	The number of times Cell Module Over-heat protection has been activated. Additionally contains the timestamp of the last occurrence.
25	Leakage protection count	The number of times Insulation Fault protection has been activated. Additionally contains the timestamp of the last occurrence.
26	No cell comm. protection count	The number of times No Cell Communication protection has been activated. Additionally contains the timestamp of the last occurrence.
27	Low voltage power reduction count	The number of times Low Cell Voltage reduction has been activated. Additionally contains the timestamp of the last occurrence.
28	High current power reduction count	The number of times High Discharge Current reduction has been activated. Additionally contains the timestamp of the last occurrence.

29	High cell module temperature power reduction count	The number of times High Cell Module Temperature reduction has been activated. Additionally contains the timestamp of the last occurrence.
30	Charger connect count	The number of time charger connection has been acknowledged.
31	Charger disconnect count	The number of times charger disconnection has been acknowledged
32	Pre-heat stage count	The number of time the "Pre-Heating" stage of the charging process has been entered.
33	Pre-charge stage count	The number of time the "Pre-Charging" stage of the charging process has been entered.
34	Main charge stage count	The number of time the "Main Charging" stage of the charging process has been entered.
35	Balancing stage count	The number of time the "Balancing" stage of the charging process has been entered.
36	Charging finished count	The number of time the "Charging Finished" stage of the charging process has been entered.
37	Charging error occurred	The number of time the "Charging Error" stage of the charging process has been entered.
38	Charging retry count	The number of times the entering condition of the "Charging Error" stage of the charging process has been automatically cleared.
39	Trips count	The number of times the recorded driven distance was more than zero between two consecutive charge connection acknowledgments.
40	Charge restarts count	The number of times the charging process automatically restarted when maximum cell voltage dropped below "Charger Restart Voltage" parameter value.
41-45	Reserved for future use	
46	Cell overheat protection count	The number of times Cell Over-heat protection has been activated. Additionally contains the timestamp of the last occurrence.
47	High cell temperature power reduction count	The number of times High Cell Temperature reduction has been activated. Additionally contains the timestamp of the last occurrence.
48	Min Cell Temperature	The lowest recorded cell temperature. Additionally contains the corresponding cell ID and timestamp of when this value was recorded.
49	Max Cell Temperature	The highest recorded cell temperature. Additionally contains the corresponding cell ID and timestamp of when this value was recorded.
50	Max Cell Temperature Difference	The highest recorded difference between cell temperatures. Additionally contains the corresponding minimum and maximum cell temperatures, ID of the cell with minimum temperature, and timestamp of when these value were recorded.
51	Secure statistics resolution*	Each bit of the value stored by this statistic indicates if the normal range of the corresponding secure statistic (ID 1 to 7) has overflowed and its resolution has been decreased.
52	No current sensor protection count	The number of times No Current Sensor protection has been activated. Additionally contains the timestamp of the last occurrence.
53	Heater activation count	The number of times the general purpose output pin mapped with "PF5 Heater Enable Output" pin function has been activated.

Most of the statistics can be cleared from the Control Panel or by sending a certain command to the Control Unit via USB, RS232, or CAN interface. However, the ones that store accumulated values and indirectly indicate the battery's state of health (marked with "*" in the Table 3.1) are considered "secure", and can only be cleared by performing the "Master Clear" procedure. More detailed information about clearing the statistics and performing the "Master Clear" procedure can be found in the "Maintenance" section.

The statistics, depending on the type of data they contain, are stored in the non-volatile memory differently:

- Secure statistics are stored in the non-volatile memory identical manner as the periodically backed up non-volatile status values (such as Battery Charge);
- Non-secure statistics that contain directly measured and therefore quite frequently changing values (e.g. Max Cell Voltage) are stored in a similar fashion as the secure statistics, except that they are not stored in non-volatile RAM, only in EEPROM;
- All other statistics are stored directly in EEPROM memory.

3.2.10 Events

During operation, EMUS G1 Control Unit keeps a log of the most recent events in its internal non-volatile memory. It consists of 32 entries, each of which stores an event type identifier and occurrence timestamp. Once all 32 entries are filled, any new event replaces the oldest entry. All event types are described in the Table 3.2.

Table 3.2: List of events and their descriptions

ID	Event	Description
1	BMS Started	BMS Unit powered up or restarted
2	Lost communication to cells	"No Cell Communication" protection has been activated
3	Established communication to cells	"No Cell Communication" protection has been deactivated
4	Cells voltage critically low	"Cell Under-Voltage" protection has been activated
5	Critical low voltage recovered	"Cell Under-Voltage" protection has been deactivated
6	Cells voltage critically high	"Cell Over-Voltage" protection has been activated
7	Critical high voltage recovered	"Cell Over-Voltage" protection has been deactivated
8	Discharge current critically high	"Discharge Over-Current" protection has been activated
9	Discharge critical high current recovered	"Discharge Over-Current" protection has been deactivated
10	Charge current critically high	"Charge Over-Current" protection has been activated
11	Charge critical high current recovered	"Charge Over-Current" protection has been deactivated
12	Cell module temperature critically high	"Cell Module Over-Heat" protection has been activated
13	Critical high cell module temperature recovered	"Cell Module Over-Heat" protection has been deactivated
14	Leakage detected	The Leakage Sensor Input pin became Active
15	Leakage recovered	The Leakage Sensor Input pin became Inactive
16	Warning: Low voltage - reducing power	"Low Cell Voltage" protection has been activated
17	Power reduction due to low voltage recovered	"Low Cell Voltage" protection has been deactivated
18	Warning: High current - reducing power	"High Discharge Current" protection has been activated
19	Power reduction due to high current recovered	"High Discharge Current" protection has been deactivated

20	Warning: High cell module temperature - reducing power	"High Cell Module Temperature" protection has been activated
21	Power reduction due to high cell module temperature recovered	"High Cell Module Temperature" protection has been deactivated
22	Charger connected	EMUS G1 Control Unit has acknowledged charger connection
23	Charger disconnected	EMUS G1 Control Unit has acknowledged charger disconnection
24	Started pre-heating stage	Pre-heating charging stage has been started
25	Started pre-charging stage	Pre-charging charging stage has been started
26	Started main charging stage	Main charging charging stage has been started
27	Started balancing stage	Balancing stage has been started
28	Charging finished	Charging process has successfully completed
29	Charging error occurred	Charging process has stopped unexpectedly due to an error
30	Retrying charging	Charging error condition has been cleared, charging process has been resumed
31	Restarting charging	Charge restart condition was met, charging process has been restarted
32-41	Reserved for future use	
42	Cell temperature critically high	"Cell Over-Heat" protection has been activated
43	Critically high cell temperature recovered	"Cell Over-Heat" protection has been deactivated
44	Warning: High cell temperature - reducing power	"High Cell Temperature" protection has been activated
45	Power reduction due to high cell temperature recovered.	"High Cell Temperature" protection has been deactivated

3.2.11 Vehicle speed measurement

Using the SPEED IN input mapped with the corresponding special "PF1 Speed Sensor Input" pin function, the Control Unit can register the pulses of the vehicle's speed signal as well as the duration between them. This data is sampled at a rate of 100Hz (in sync with the current measurement), and each time the ratio between the pulse count and the total duration between them is divided by the value of "Pulses per Distance Unit" parameter in order to determine the momentary vehicle speed. This value is not essential to the core functions of the BMS, however it is used for keeping track of the total driven distance and distance since charge, calculating the energy consumption per distance unit, and estimating the remaining distance. All of these values can be read from the Control Unit through one of its digital interfaces and monitored in real time on EMUS G1 Display Unit or a third party display, which eliminates the need for a separate electronics for these functions and allows to simplify the electrical system of the vehicle.

3.2.11.1 Energy consumption calculation

EMUS G1 Control Unit uses the measured vehicle speed or other values derived from it to calculate three different types of energy consumption per distance unit:

- Momentary Consumption;
- Average Consumption;
- Last Trip Average Consumption;

Momentary Consumption is updated every 10 milliseconds by using the formula (5), in which $I_{Momentary}$ is the momentary current value, $V_{Momentary}$ is the momentary battery pack voltage value, and $v_{Momentary}$ is the momentary vehicle speed value.

$$\text{Momentary Consumption} = \frac{I_{Momentary} \cdot V_{Pack}}{v_{Momentary}} \quad (5)$$

A digital, first order low pass Butterworth filter with a cutoff frequency of 0.03Hz is also applied before storing the final result in the volatile memory in order to smooth out any fluctuations. In case the momentary vehicle speed value is equal to zero, the momentary consumption is set to 0xFFFFFFFF, which should be interpreted as N/A (not available).

Average Consumption is calculated using the formula (6), in which Total discharge energy is the momentary value of the corresponding statistic, and Discharge energy at the end of last charge is a non-volatile status value that is updated each time a charger disconnection is acknowledged. In contrast to periodically backed up non-volatile statuses like Battery Charge, this value belongs to another group of non-volatile status values that don't change too often and are therefore stored directly in EEPROM memory.

$$\text{Average Consumption} = \frac{\text{"Total discharge energy"} - \text{"Discharge energy at the end of last charge"}}{\text{"Distance Since Charge"}} \quad (6)$$

Distance Since Charge is a periodically backed up non-volatile status value that is updated with each registered pulse of the vehicle speed signal, and cleared by setting to zero each time charger is connected. Similarly to Momentary Consumption, Average Consumption is set to 0xFFFFFFFF to indicate that it is not available if Distance Since Charge is equal to zero or not available.

Last Trip Average Consumption is calculated using the formula (7), in which Last Discharge Energy is another non-volatile status value stored directly in EEPROM, that is updated by subtracting the Discharge energy at the end of last charge value from the value of Total discharge energy statistic each time a charger connection is acknowledged.

$$\text{Last Trip Average Consumption} = \frac{\text{"Last Discharge Energy"}}{\text{"Previous Driven Distance"}} \quad (7)$$

Previous Driven Distance is an EEPROM-only non-volatile status value too, and is updated every time a charger connection is acknowledged by copying the Distance Since Charge value just before it is cleared. Just as with the other two types of energy consumption, Last Trip Average Consumption is set to 0xFFFFFFFF to indicate that it is not available if Previous Driven Distance is equal to zero or not available.

3.2.11.2 Remaining distance estimation

EMUS G1 Control Unit estimates the remaining distance based on the calculated values of energy consumption per distance unit, and by assuming that the ratio between the energy remaining in the battery and energy already used in during the current trip is equal to the ratio between the remaining SOC and SOC used since the start of the trip. It results in three different values of remaining distance, all of which are determined using the formula (8), in which SOC At Start Of Trip is a periodically backed up non-volatile status value that is updated each time a

$$\text{Distance Left} = \frac{\text{"SOC"} \cdot \left(\frac{\text{"Total discharge energy"} - \text{"Discharge energy at the end of last charge"}}{\text{"Consumption"}} \right) \cdot (100 - \text{"Safety Margin"})}{100 \cdot \text{"SOC At Start Of Trip"} - \text{"SOC"}} \quad (8)$$

charger disconnection is acknowledged, by copying the SOC value that is present at that time. Safety Margin is the value of a corresponding configuration parameter which allows to reduce the result as

a precaution from possible estimation inaccuracy. Consumption in each particular case is equal to the value of Momentary Consumption, Average Consumption, or Last Trip Average Consumption. In case this value is not available or equal to zero, or SOC At Start Of Trip is equal to SOC, the corresponding Distance Left is set to 0xFFFFFFFF to indicate that it is not available.

3.2.12 Communication with external devices

EMUS G1 Control Unit Serial and CAN communication protocols are open-source. These protocols can be integrated into external devices in order to provide direct communication with EMUS G1 Control Unit. Protocols are available in our website <https://emusbms.com/support>

3.2.13 Indication

EMUS G1 Control Unit can provide an audiovisual charging and critical condition indication when connected to the appropriate pins. Each case can be identified by a different pulse pattern. All available indications are described in further sections.

3.2.13.1 Charging status indication

An LED or a lamp connected to any general purpose output pin mapped with "PF9 Charging Indication Output" pin function will visually indicate the charging status by blinking certain patterns. The blinking patterns are shown in the Figure 3.15.

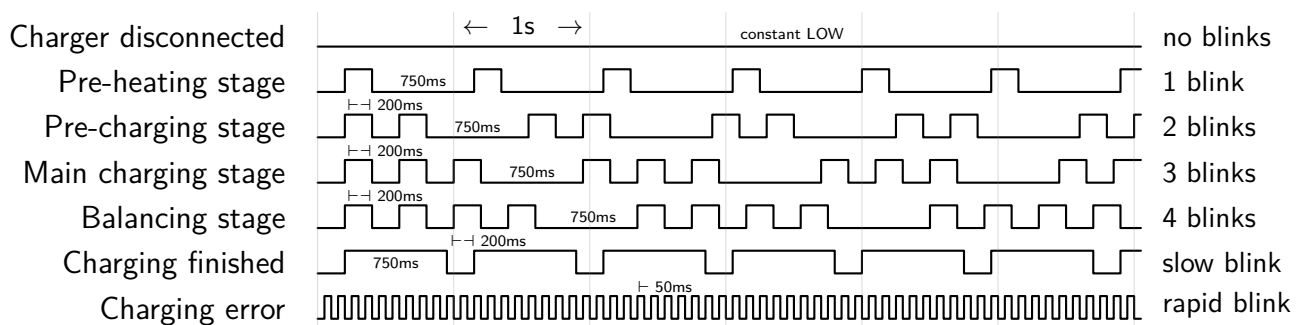

Figure 3.15: Charging indicator timing

3.2.13.2 Buzzer

A self-oscillating buzzer connected to any general purpose pin mapped with "PF7 Sound Buzzer Output" pin function will provide an audial indication of the following conditions:

- "Low Cell Voltage" reduction is active.
- Charging error occurred.

Pulse patterns are shown in the Figure 3.16.

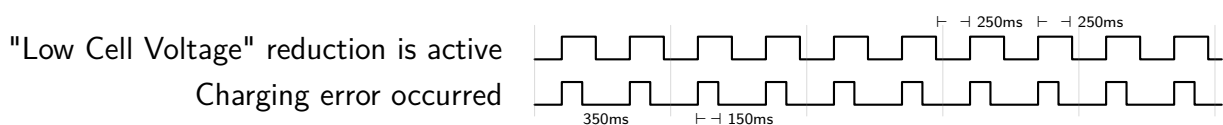

Figure 3.16: Sound indicator timing

3.2.13.3 Low battery indication

An LED or a lamp connecto to any general purpose output pin mapped with "PF8 Battery Low Indication Output will visually indicate the following conditions:

- Minimum cell voltage is below the "Low Cell Voltage" reduction "Activate at" threshold.
- Average cell voltage is below the "Low Cell Voltage" reduction "Activate at" threshold.

Pulse patterns are shown in the Figure 3.17.

Minimum cell voltage is below the "Low Cell Voltage" reduction "Activate at" threshold

Average cell voltage is below the "Low Cell Voltage" reduction "Activate at" threshold

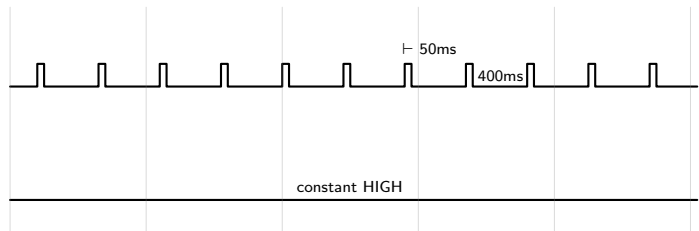

Figure 3.17: Low battery indicator timing

4 Installation

Correct EMUS G1 BMS installation will prevent both immediate and delayed issues in the system, yet requires certain knowledge to be carried out as intended, therefore it is necessary to strictly follow the instructions described in the following chapters during the process. Also, because some parts of the installation process requires working near exposed energized parts, it is extremely important to undertake the all necessary safety precautions (like wearing insulating gloves, using insulated tools, etc.) in order to avoid injuries, damage to the BMS components, or other unexpected harmful consequences. It should be carried out only by a qualified employee who has carefully read through this whole section and thoroughly understands all the risks involved when working with lithium cells.

4.1 Control Unit

EMUS G1 Control Unit should be tightly secured to a surface using screws, as shown in figure 4.1. It is recommended to install it small distance away from the battery (ideally in the same enclosure) in order to make the wiring process easy and to keep the wires between different EMUS G1 BMS components short. The wiring process should start by connecting the Control Unit to its power source (several different strategies on how to provide power to EMUS G1 BMS are described in sub-chapter 4.1.1). Wires coming from the power source should be stripped, crimped with the provided crimp contacts using an appropriate crimp tool, and inserted into the corresponding slots on the Control Unit's main 22 pin connector. Since no outputs dedicated for powering other EMUS G1 BMS or third party components are populated on any of the Control Unit's connectors for space saving and simpler design purposes (except for the Current Sensor), power should distributed using external means, as shown in the example in figure 4.1.

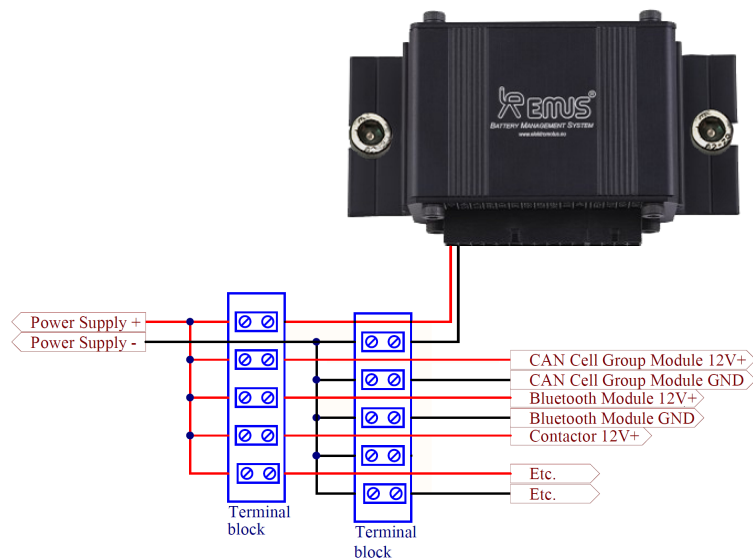
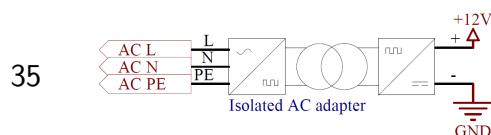

Figure 4.1: Correct installation of Control Unit and distribution of power supply to other EMUS G1 BMS components

4.1.1 Choosing the power supply strategy

Depending on whether the application requires the battery to be operated continuously or with idling periods, and whether the application guarantees a constant grid power availability or not, three different strategies of supplying power to EMUS G1 Control Unit can be recommended:



1. In applications that guarantee constant grid power availability (i.e. domestic energy storage systems for increasing self-consumption from solar panels or wind turbines, industrial energy storage systems for peak shaving, fast charging stations, etc.), it is recommended to supply power to the Control Unit and the rest of EMUS G1 BMS components from the grid using an appropriate isolated AC adapter, as shown in the example in figure 4.2a;
2. In applications that do not guarantee constant grid power availability, yet do not require the battery to be in operation constantly either (i.e. various electric vehicles and other mobile application), it is recommended to supply power to the Control Unit and the rest of EMUS G1 BMS components from an auxiliary 12V battery that is charged from the main battery through an isolated DC/DC converter, as shown in the example in figure 4.2b. In this example EMUS G1 Control Unit is connected to the auxiliary battery either when the ignition key is turned on or when an on-board charger is connected to the grid, and controls the relay that disconnects the DC/DC converter from the main battery with one of the Control Unit's general purpose pins mapped with "PF24 DC/DC Control Output" function. This ensures that EMUS G1 Control Unit does not drain the auxiliary nor the main battery when the system is not in operation, and also protects the main battery from damage due to depletion in case the operator forgets to turn off the ignition key and leaves the system to idle for an extended period of time. It is also important to mention that in the system given in this example the auxiliary battery and DC/DC converter most likely powers not only EMUS G1 Control Unit, but also a whole network of other devices, therefore it is recommended to use a diode (marked as D2 in this example) that prevents bypassing of the ignition key when the on-board charger is connected to the grid.
3. In applications that do not guarantee constant grid power but require the battery to be constantly in operation (i.e. off-grid energy storage systems, various backup energy systems, etc.), it is recommended to supply power to the Control Unit and the rest of EMUS G1

BMS components from the same battery that it manages directly through an isolated DC/DC converter. In this case the DC/DC converter is most likely dedicated to powering only EMUS G1 Control Unit and draws very low current from the battery, therefore it can be connected to it or disconnected from it without using an auxiliary battery, as shown in the example in figure 4.2c. In this example the system is turned on manually by pressing the start button that connects the DC/DC converter to the battery, and holding it until the Control Unit activates the general purpose output mapped with "PF24 DC/DC Control Output" function. It is turned off either manually by pressing the stop button, or automatically if the BMS detects that cell voltages have fallen below the corresponding configurable threshold.

Regardless of the chosen strategy, the dimensioning and selection of the components for the power supply sub-circuit depends on various aspects of the system in which the battery is used, and is out of the scope of this document.

4.2 Cell Modules

EMUS G1 Cell Modules are designed to be mounted directly on the cell terminals together with the interconnecting bus bars and power cables, therefore they should be installed during the battery assembly process. The battery side wires of the cell communication adapters have to be connected during this process as well.

Before starting the installation it is recommended to sand the aluminum and copper contact surfaces of the cell terminals, interconnecting bus bars, and power cable terminal lugs with fine sandpaper (180 to 240 grit) in order to ensure good electrical contact between the cells and the Cell Modules. Once sanding is complete, it is necessary to thoroughly clean off the resulting metal dust, as well as any remaining dirt, grease, or moisture afterwards. Also, the cell communication adapters should be prepared prior to installation by stripping the ends of the wires that will connect to the plus or minus terminal of the cell (shown in figure 4.3), crimping them

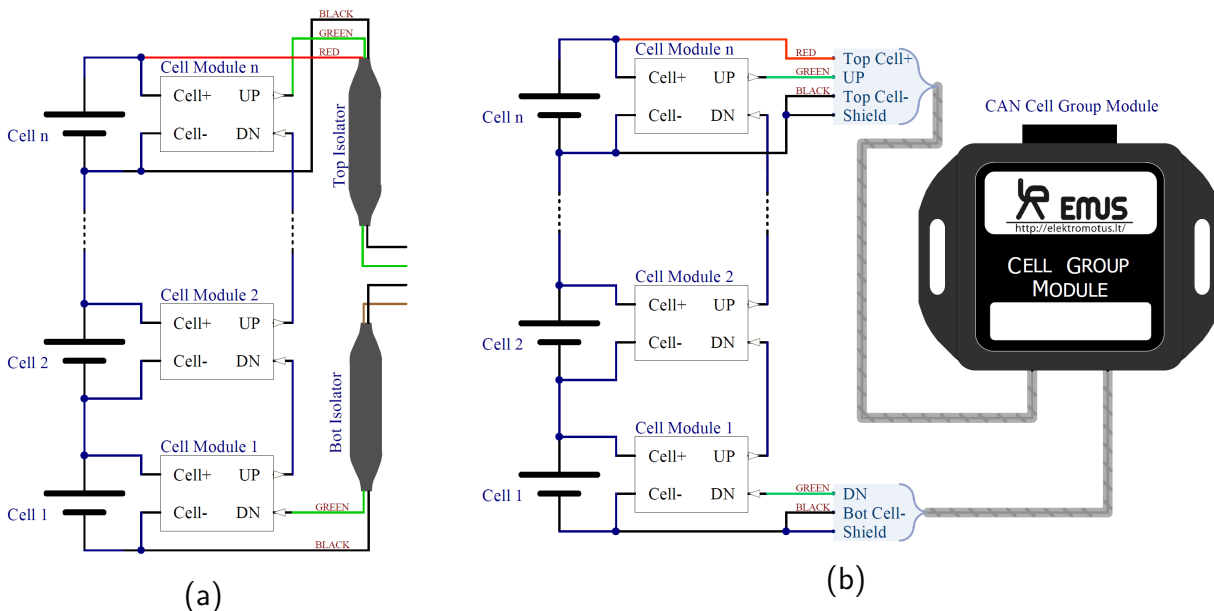

Figure 4.3: Correct way of wiring a cell communication daisy chain: (a) Top and Bottom Isolators; (b) CAN Cell Group Module.

with provided the ring terminals using an appropriate crimp tool, and then isolating all battery side wires with electrical tape in order to avoid unintentional damage in case the wires are accidentally dropped across several cells. Then, the power cables/interconnecting bus bars, Cell Modules, cell communication adapter plus and minus wires, and fixing elements should be installed

on each cell in the following order:

1. Interconnecting bus bar or terminal lug of the power cable;
2. Cell Module;
3. Cell communication adapter negative and positive wire ring terminals;
4. Washer;
5. Spring washer;
6. Bolt.

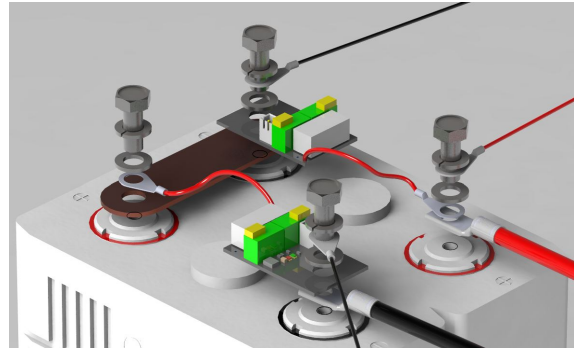

Figure 4.4: Correct EMUS G1 BMS Cell Module installation order

Special attention should be paid to ensure that the Cell Module polarity matches the polarity of the cell. Connecting the Cell Module to the cell in reverse order or across more than one cell even for a short period of time may permanently damage the Cell Module. In order to avoid over-tightening the bolts and breaking the Cell Module, an adjustable torque wrench should be used, and the bolts should be tightened according to the recommendations in table 4.1. While tightening the bolts it should also be observed that the wrench would not touch the electrical components of the Cell Module and knock them off, or damage them in any other way.

Once the interconnecting bus bars and Cell Modules are properly installed, the cell communication daisy chain can be wired. In order to reduce the risk of damaging the Cell Modules in case the cell communication wires are connected incorrectly, it is strongly advised to start by connecting the green communication wire of the bottom cell communication adapter to the

Table 4.1: Recommended cell terminal bolt tightening torque

No.	Terminal bolt type	Recommended tightening torque (N·m)
1	M5	10
2	M6	12
3	M8	14
4	M14	24

"DN" input of the first Cell Module. Then the wiring process should be continued by successively connecting the "UP" output of each Cell Module to the "DN" input of the next Cell Module, and finished by connecting the green communication wire of the top cell communication adapter to the "UP" output of the last Cell Module. It is also important to note that for safety reasons, no load, utility, or charging device should be connected to the battery until the cell communication daisy chain(s) has been properly wired.

Furthermore, no contactors, fuses, or other disconnection devices should be installed between two cells if their Cell Modules belong to a single cell communication daisy chain, since an electric circuit between the battery and any device connected to it then closes through the cell communication wire, which produces a very high risk of irreversible damage to the Cell Modules and shock hazard when working near the battery terminals. If the battery needs to be disassembled for any reason, the cell communication daisy chain should be taken apart and the Cell Modules should be removed beforehand.

In case Small, CAM72, or GBS model Cell Modules that have pre-soldered cell communication wires instead of terminal blocks are used, the recommended method for joining the cell communication wires together is using 3M™ Scotchlok™ butt connectors (a.k.a jelly crimps), since it is a very quick, easy, and safe way to make a reliable electrical contact without using special tools. The reliability, however, will be achieved only when the correct connectors for used wire gauge are used, and instructions of correct use are followed:



Figure 4.5: 3M™ Scotchlok™ butt connector

1. Straighten the wire ends and trim them if necessary, but do not strip them;
2. Fully insert the wires ends into the connector;
3. Place the connector between pliers in such way that the wires would be sticking out in the same direction as the pliers are pointing;
4. Firmly press down the cap of the connector with a single quick motion.

This will ensure that both wires are crimped at the same time, and that a cold weld is formed. Excessive force should not be used to avoid crushing the connector through, as this will compromise its sealing properties and might cut off the wires.

4.3 Current Sensor

EMUS G1 Current Sensor, regardless of its type, should be installed in such way that all currents going in and out of the battery would flow through it (i.e. behind all load, charging, or utility devices that are connected to the battery). When using the Bus Bar type Current Sensor, additional care should be taken to install it away from any sources of heat or stray magnetic fields (permanent magnets, power cables, etc.), and without bending or twisting its conductor,

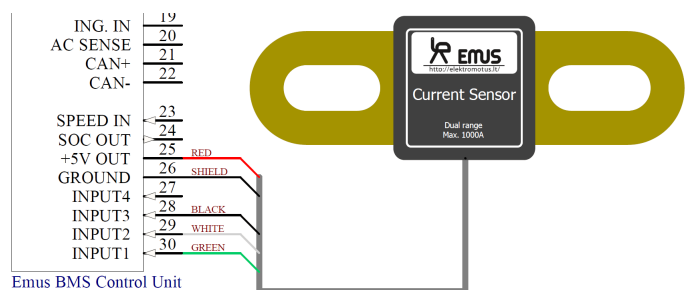
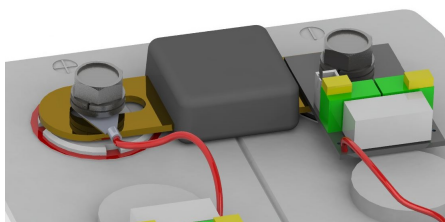
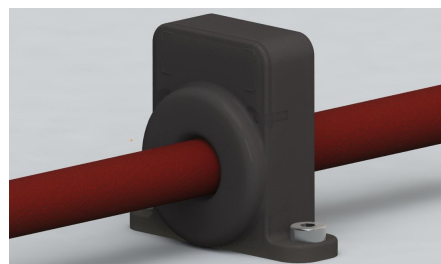

Figure 4.6: EMUS G1 Current Sensor connection diagram. The Closed Loop type Current sensor connects identically.

since all of these factors may affect its calibration accuracy. Ideally it should be installed as an interconnecting bus bar between two adjacent prismatic form factor cells that are fixed and cannot move vertically relative to each other, as shown in figure 4.7a. The Closed Loop type Current Sensor is more rugged than the Bus Bar type in a number of ways, however it is still recommended to place it away from any sources of heat or stray magnetic fields. It should be installed by securing it to a surface and threading one of the battery power cables through it. The battery cable should then be secured to the surface in such way that it would not exert any bending force on the sensor. Once the Current Sensor is installed, it can be connected to the Control Unit by plugging its cable directly into the 8 pin connector. The cable should then be secured to a surface in such way that it would not be strained, and would not go alongside the power cables in order to avoid interference. Plastic cables ties and adhesive cable tie holders are recommended for securing it.



(a)



(b)

Figure 4.7: Correct EMUS G1 Current Sensor installation: (a) Bus Bar type; (b) Closed Loop type.

4.4 Cell Communication Adapters

EMUS G1 Top and Bottom Isolators should be connected to the Control Unit as shown in figure 4.8. The ends of the corresponding Isolator should be stripped and crimped with the crimp contacts that are provided with the Control Unit using an appropriate crimp tool, and inserted into corresponding slots on the main 22 pin connector. The battery side wires of the Top and Bottom Isolators should be installed together with the Cell Modules, therefore the instructions on how to connect them are provided in chapter 4.2. The wires of on each end of the Isolators can be shortened or extended if necessary, however it is not recommended to extend them over 0.5m. Once connected, the Isolators should be secured to a surface in such way that their wires would not be strained, and would not go alongside the power cables in order to avoid interference due to capacitive coupling. The recommended method for securing the Isolators in place is using plastic cables ties and adhesive cable tie holders.

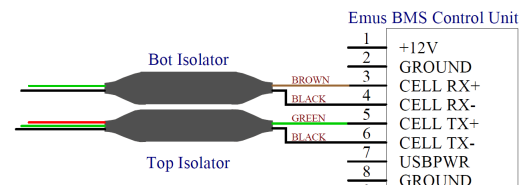

Figure 4.8: Correct way of connecting the Top and Bottom Isolator to the Control Unit.

Similarly to the Top and Bottom Isolator, instruction on how to connect the battery side cable wires of a CAN Cell Group Module are described in chapter 4.2, while connecting the CAN Cell Group Module(s) to the Control Unit should be done following the general rules of correct CAN bus setup, which also apply to other CAN equipped devices in the system and are therefore abstractly described separately in chapter 4.5.

4.5 CAN Bus

The CAN bus has been widely adopted in industrial, automotive, and instrumentation applications due to the inherent strengths of its communication mechanisms, however its reliability will be compromised if it is not set up correctly. CAN-equipped EMUS G1 BMS components are designed to be used in high-speed CAN networks, such as the one specified by the ISO 11898-2 standard. This standard defines a single line structure network topology in which the bus lines are terminated at their furthest ends by a single termination resistor, as shown in figure 4.9.

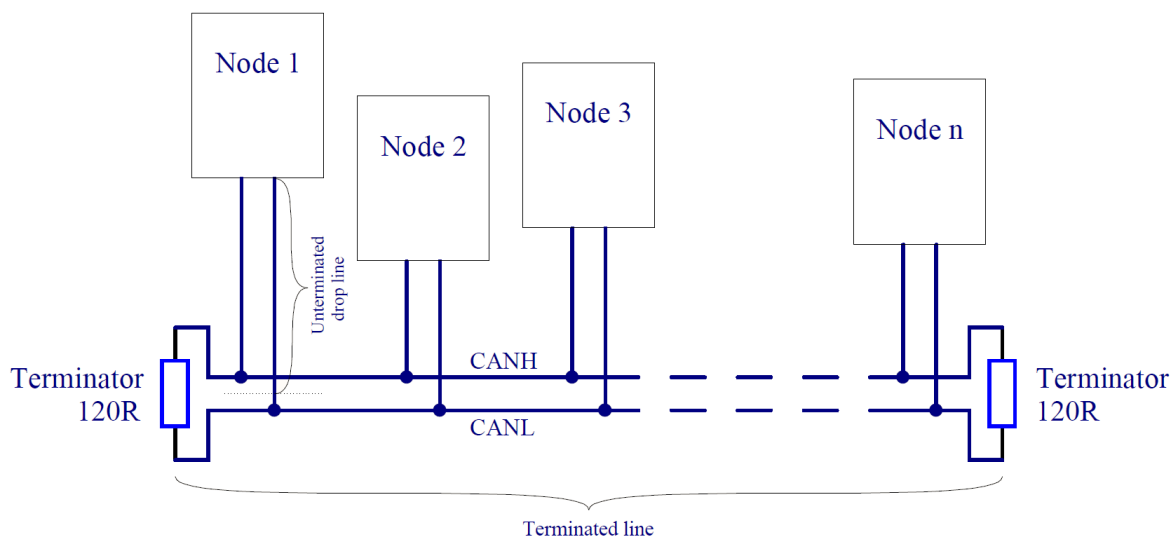

Figure 4.9: High-speed CAN network specified in ISO-11898-2 standard

The maximum total bus length and maximum lengths of a single unterminated drop line and

all unterminated drop lines together of a CAN network to which EMUS G1 BMS components are connected are presented in the Table 4.2. Maximum total bus length is essentially limited by propagation delays of the used CAN transceiver and transmission line, and CAN bit timing settings used in CAN-equipped EMUS G1 BMS components. In practice however, lengths with which CAN communication is reliable may be lower due to use of low grade cables or a high number of connected nodes, therefore it is recommended to choose the length with the maximum possible reserve when designing the CAN network. It is also important to note that unterminated drop lines contribute to the total bus length and thus limit the maximum length of the terminated line.

Table 4.2: Maximum bus line lengths, calculated based on the used CAN bit timing setting, considering that a twisted-pair cable with a typical propagation delay of 5 ns/m is used. L_U - maximum length of a single unterminated drop line, $\sum L_U$ - maximum length of all unterminated drop lines together.

Baud rate	L_U	$\sum L_U$	Max total bus length
1 Mbit/s	2 m	10 m	20 m
800 kbit/s	3 m	15 m	32 m
500 kbit/s	3 m	15 m	45 m
250 kbit/s	6 m	30 m	120 m
125 kbit/s	12 m	60 m	270 m
50 kbit/s	32 m	160 m	770 m

Ideally the topology of the actual CAN network should be as close as possible to a single line structure, since unterminated drop lines cause signal reflections to occur on the bus, and the longer they are, the more likely it is for the reflections to continue long enough to cause the node receivers to misread the signal levels. In practice however, the network is often designed to slightly deviate from ideal topology for easier installation, yet the both the length of a single drop line and the cumulative length of all drop lines on the bus should not exceed certain limits, otherwise the reflections may cause communication errors even though the line is properly terminated. The maximum values of these lengths in Table 4.2 are calculated based on the bit timing settings used in CAN-equipped EMUS G1 BMS Components, which were chosen according to the recommendations in CiA (CAN in Automation) 301 standard, and are optimal when nodes from different manufacturers are connected to the same CAN network.

According to high-speed transmission specification in ISO11898-2 standard, both ends of the CAN bus must be terminated in order to minimize reflections and ensure that both lines are correctly returned to a recessive state, because any node on the bus may transmit data. The termination resistors should match the characteristic impedance of the cable, although the recommended value is nominally 120Ω (100Ω minimum and 130Ω maximum). There should not be more than two terminating resistors in the network, regardless of how many nodes are connected, because additional terminations place extra load on the drivers. ISO-11898-2 standard also recommends not integrating a terminating resistor into a node but rather using standalone termination resistors. This concept helps to avoid a loss of a termination resistor if a node containing that resistor is disconnected, and prevents connecting more than two of them to the bus or locating them at other points in the bus rather than at the furthest ends.

Maximum number of nodes in a CAN network is limited by their finite differential input resistance that loads the line and decreases the signal amplitude, therefore it depends on the driving capability of the used CAN transceiver. The manufacturer of the transceivers used in CAN-equipped EMUS G1 BMS components specifies that it will drive a minimum load of 45Ω, allowing a maximum of 112 nodes to be connected, given that the differential input resistance of each node on the bus is not less than 20kΩ and 120Ω termination resistor are used.

In order to ensure the robustness and reliability of the CAN network regardless of the conditions

in which it will be used, it is recommended to use a shielded twisted pair cable to implement it. Due to space saving reasons the CAN interface is populated only on a single connector in all CAN-equipped EMUS G1 BMS components, therefore they should be connected to the bus either at its ends, or by branching the bus cable somewhere in the middle. When using the latter method, each wire of the branch cable, including the shield, should be connected to corresponding wire of the main bus cable by using a T connector, wire tap splices, or in the worst case, by soldering the wires together and covering them in heat-shrink tube. The shield should be grounded at a single point only, ideally as close as possible the output of the power supply that powers the nodes connected to the CAN network in order to avoid ground loops.

4.6 Smartphone Connectivity Module

EMUS G1 Smartphone Connectivity Module should be installed by connecting it to the Control Unit as shown in figure 4.10. The end of each wire of the Bluetooth Module cable should be stripped and, depending on its purpose, either crimped with the crimp contacts that are provided with the Control Unit using an appropriate crimp tool and inserted into corresponding slots on the main 22 pin connector, or connected to the same power supply that powers the Control Unit. Once all the wires are connected, the G1 Smartphone Connectivity Module should be placed in an appropriate spot where it is not covered by any objects that could obstruct its signal (e.g. metal enclosures), and secured to a surface. It is also recommended to secure its cable to a surface using plastic cables ties and adhesive cable tie holders in such way that it would not be strained.

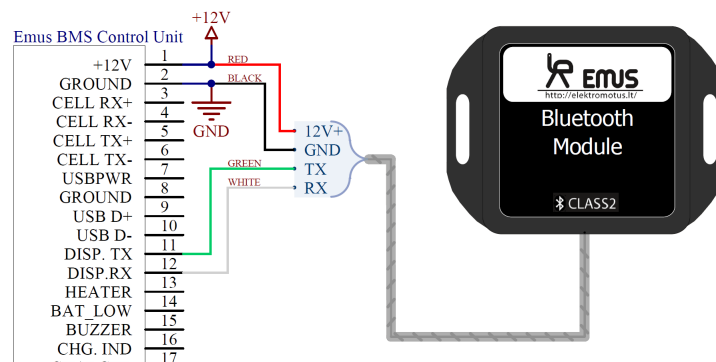

Figure 4.10: EMUS G1 Smartphone Connectivity Module connection diagram

4.7 Display unit

EMUS G1 Display Unit should be connected to the Control Unit as shown in figure 4.11. The end of each wire of the Display Unit cable should be stripped and depending on its purpose, either crimped with the crimp contacts that are provided with the Control Unit and inserted into corresponding slots on the main 22 pin connector, or connected to the same power supply that powers the Control Unit. RS-232 connector on the Display Unit consists of 4 pins. Once the wires are connected, the Display Unit should be secured to a surface in such way that its wires would not be strained, by using plastic cables, adhesive cable tie holders and screws or bolts.

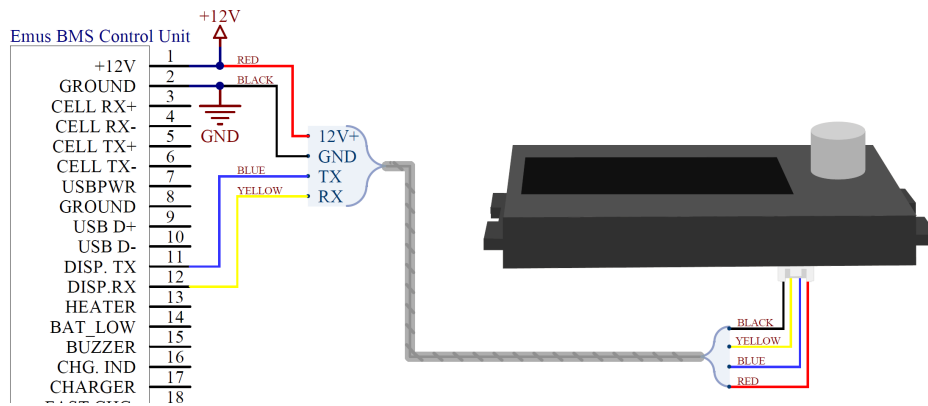

Figure 4.11: EMUS G1 Display Unit wiring

4.8 Battery fuse

In order to protect the battery and the system in which it is used from unpredictable, potentially destructive consequences of contactor failure (e.g. welding), load or charging device failure, short circuit, or other similar cases, it is necessary to install a battery fuse behind the main contactor as shown in figures 4.12 and 4.13. The dimensioning of the fuse depends on various aspects of the system in which the battery is used, and is out of the scope of this document.

4.9 Contactor

The main contactor should be installed behind all load devices, and its coil terminals should be connected directly between Control Unit's power supply positive terminal and one of the general purpose outputs of Control Unit that is mapped with appropriate pin function, as shown in figure 4.12. If the rated current of the contactor coil is 0.5A or more, additional signal relay should be used to drive the contactor. The dimensioning of the contactor depends on various aspects of the system in which the battery is used, and is out of the scope of this document

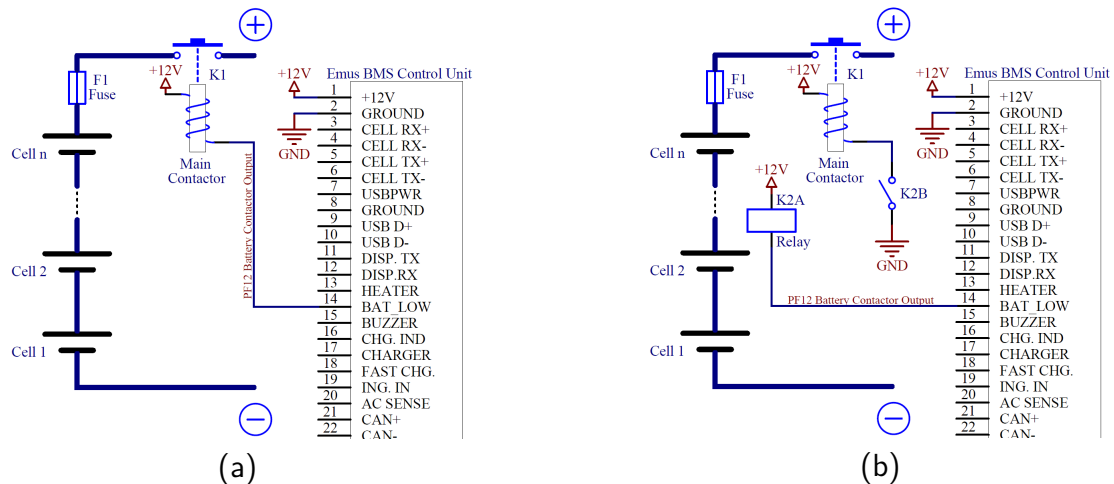

Figure 4.12: Connecting contactor to EMUS G1 Control Unit: (a) directly, when the rated current of the contactor coil is less than 0.5A; (b) through a relay, when the rated current of the contactor coil is 0.5A or more.

4.9.1 Pre-charge sub-circuit

The contactor pre-charge sub-circuit should consist of a relay in series with a pre-charge resistor (or another current limiting device), and should be connected in such way that it would bypass the contactor. The terminals of the contactor pre-charge relay coil should be connected directly between the positive terminal of Control Unit's power supply and one of the general purpose outputs of the Control Unit that is mapped with appropriate pin function, as shown in figure 4.13. The dimensioning of the pre-charge resistor and the pre-charge relay, as well as calculation of the actual pre-charge process duration depends on various aspects of the application, and is out of the scope of this document.

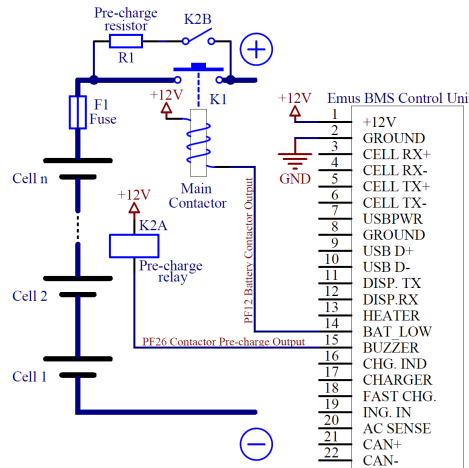

Figure 4.13: Contactor pre-charge sub-circuit connection diagram

4.10 Charger

Charging process control is one of the most important tasks that a battery management system must perform to ensure safe lithium battery operation, therefore it is very important to correctly select and connect a charging device in order allow EMUS G1 Control Unit to control it. The selection of a particular charging device should be done considering various aspects of the application, yet its output parameters are the most important from the battery management system's point of view. The maximum output voltage should be slightly higher than the cell charge voltage specified in the cell specification sheet multiplied by the number of cells connected in series, while the maximum output current should not exceed the maximum charging current specified in the same specification sheet. Correct connection of different charging devices types supported by EMUS G1 Control Unit is described in the following chapters.

4.10.1 CAN-based chargers

In order to allow EMUS G1 Control Unit to protect the battery in case a charging error occurs, a CAN charger should be connected to the battery through a separate dedicated contactor that is controlled by one of Control Unit's general purpose outputs mapped with "PF10 Charger Enable" function, as shown in figure 4.14. The connection between a CAN charger and Control Unit is shown in figure 4.14 as well, but only for reference, and should be done according to the general rules of correct CAN bus setup that are described in chapter 4.5. Most CAN chargers supported by EMUS G1 Control Unit have an internally powered isolated CAN interface and should be connected to the Control Unit as shown in the general example in figure 4.14, however in some models (e.g. Zivan chargers) the CAN interface can optionally be powered from external power supply. Correct connection depends on various aspects of the system in which the battery is used in such cases, and is out of the scope of this document. The dimensioning and selection of a charger contactor depends

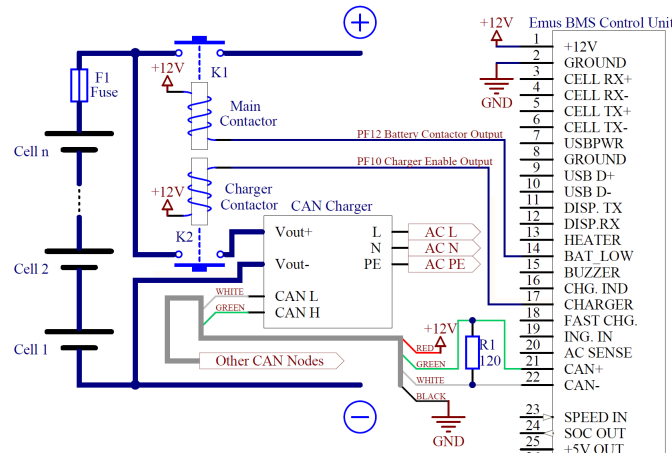

Figure 4.14: Correct battery CAN charger and charger contactor connection in respect of the battery, battery fuse, and main contactor

on the output parameters of the charger that is used, and is out of the scope of this document as well.

4.10.2 Non-CAN chargers

Non-CAN charging devices should generally be connected directly to the battery and controlled using the EMUS G1 Solid State Relay, which should be connected as shown in the example in figure 4.15a. Alternatively, if the charging device does not connect to the AC grid (for example a diesel generator or an MPPT solar charger), its input power is more than 3.5kW, or it is not compatible with the Solid State Relay for some other reason, a third-party electromechanical contactor can be used instead, as shown in the example in figure 4.15b. In such cases, the charger connection acknowledgment should be provided to the Control Unit automatically using an appropriate signal relay, or manually using a latching pushbutton or a tumbler. Dimensioning and selection of the electromechanical contactor and other necessary components should be done according to the requirements of the particular system, and is out of the scope of this document.

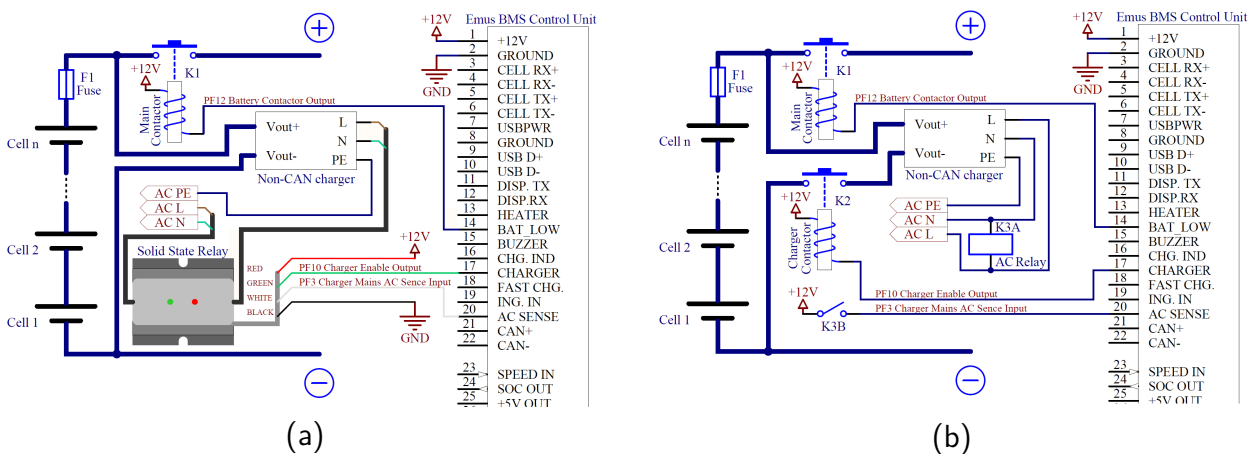

Figure 4.15: Correct connection of a non-CAN charger in respect of the battery, battery fuse, and main contactor: (a) using EMUS G1 Solid State Relay; (b) using a third-party electromechanical contactor.

4.10.3 Analog signal controlled chargers

Similarly to a CAN charger, analog signal controlled charger should be connected to the battery through a separate, dedicated contactor, as shown in the example in figure 4.16. In order to connect the charger to the Control Unit a signal conditioning sub-circuit is usually required, such as the

one shown in figure 4.16, which is designed according to the TC/Elcon charger control interface connection documentation. If another charger model is used, the signal conditioning sub-circuit may differ and should be designed according to the control signal requirements of that particular charger.

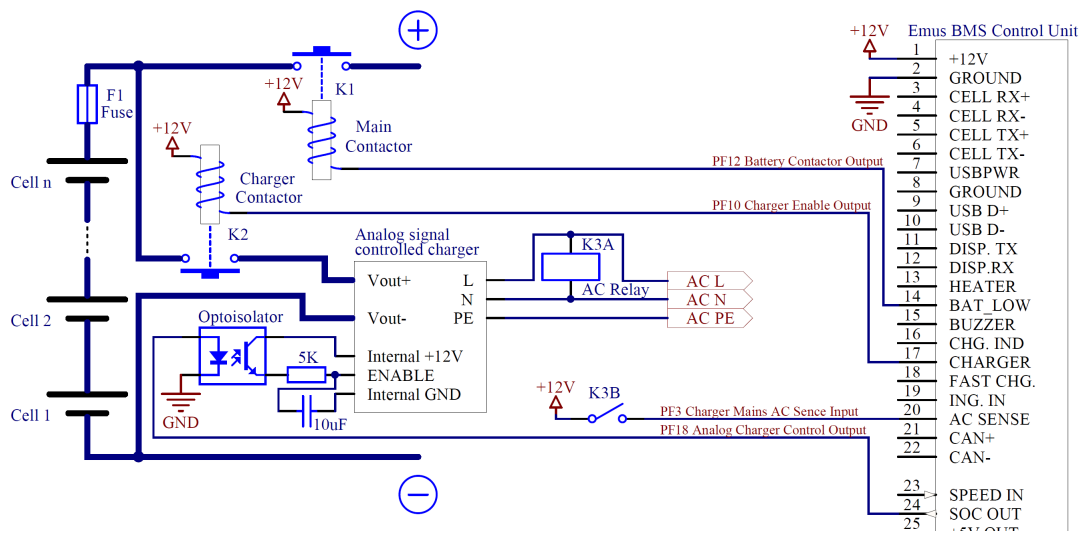

Figure 4.16: Correct analog signal controlled charger and charger contactor connection in respect of the battery, battery fuse, and main contactor

4.11 Cooling fan

Cooling fan for cooling the Cell Modules during balancing is usually requires quite low amount of power, and can be supplied from the same power supply as the Control Unit and controlled using a single relay, as shown in the example in figure 4.17. Coolant pumps of liquid battery cooling systems are usually relatively low power as well, can be connected and controlled in an identical manner. Designing a cooling system for the battery or the Cell Modules, as well as dimensioning and selection of its components is out of the scope of this document.

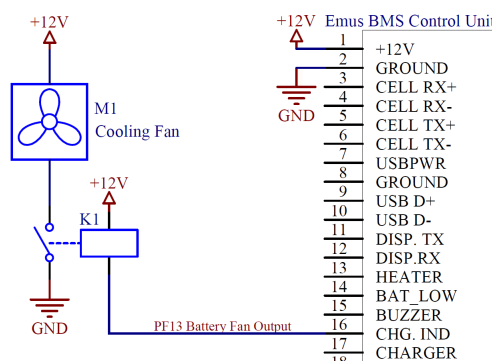

Figure 4.17: Cooling fan connection diagram

4.12 Heater

In contrast to the cooling fan, battery heater usually requires a lot of power, and due to the resulting high current it is unpractical to supply power to it from the same source as the Control Unit, therefore it is usually connected directly to the battery, and controlled using a separate, dedicated contactor, as shown in figure 4.18. Due to the heater's nature to draw constant current the contactor is

at a higher risk failing by welding, therefore it is extremely important to correctly dimension the contactor, since the battery can be potentially damaged due to overheat or over-discharge in case the heater contactor welds. A solid state relay may be used instead of an electromechanical contactor to eliminate such risk (not to be confused with EMUS G1 Solid State Relay used for controlling non-CAN charger).

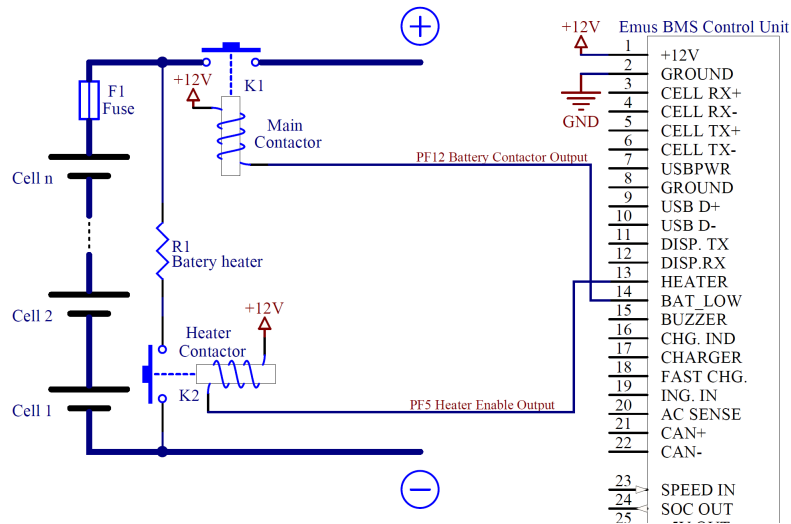

Figure 4.18: Heater connection diagram

4.13 Indicators

If they are required, discrete visual or auidial indicators should be connected between the positive terminal of the Control Unit's power supply and one of the Control Unit's general purpose outputs mapped with appropriate function, as shown in figure 4.19. An LED or an indication lamp is recommended to be used for visual indication, while the auidial indicator has to be a self-oscillating type buzzer that automatically emits sound of a warning frequency when powered. The selection of a particular indicator and dimensioning of any related components should be carried out according to the system requirements, and is out of the scope of this document.

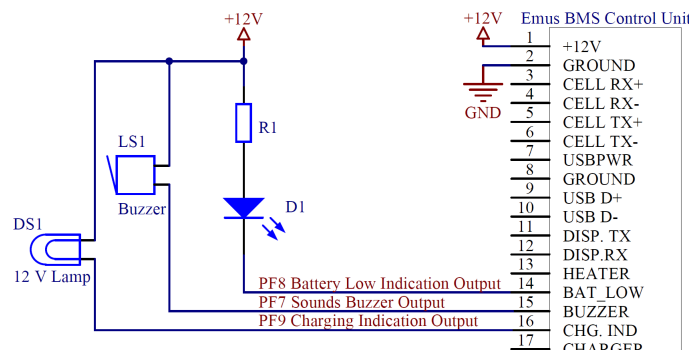

Figure 4.19: Examples of connecting visual or auidial indicators to the Control Unit (left to right): an indication lamp, a self-oscillating buzzer, and an LED.

4.14 Insulation fault detector

If required by the application, insulation fault detector should be installed in the system by connecting its corresponding inputs to the battery heater terminals, and its output to one of the Control Unit's general purpose inputs, as shown in the example in figure ?. It is important to note that Control Unit

expects a logic signal with levels of 0V and 5 to 12V respectively, therefore depending on the particular models of the detector that is used, and addition signal conditioning sub-circuit may be needed.

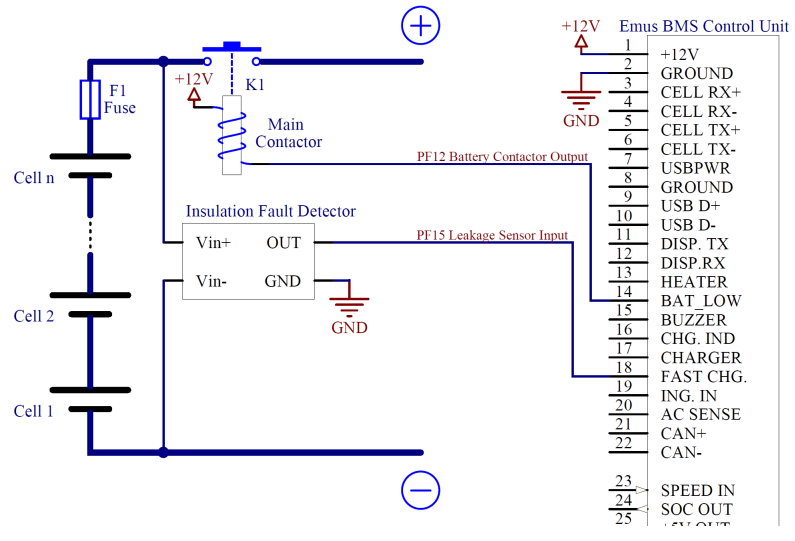

Figure 4.20: Example of connecting a third party insulation fault detector to the Control Unit.

5 Configuration

5.1 Data interfaces

Settings for data interfaces are located in Control Panel, Configuration page → General tab.

5.1.1 Serial

Serial interface settings are located in "Data Transmission to Display Period" box. By checking "Broadcast on RS232/USB" check-box, data broadcast to display over RS232/USB interface is enabled. Data transmission is divided into two states: active and sleep. Both parameters refer to display update period which defines the frequency of broadcasting the parameters via RS232/USB interface and/or CAN bus. Active and sleep states parameters accept ranges of values from 0.1 – 25.0 s and from 0.1 – 5000.0 s respectively.

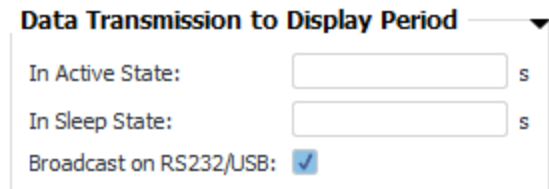
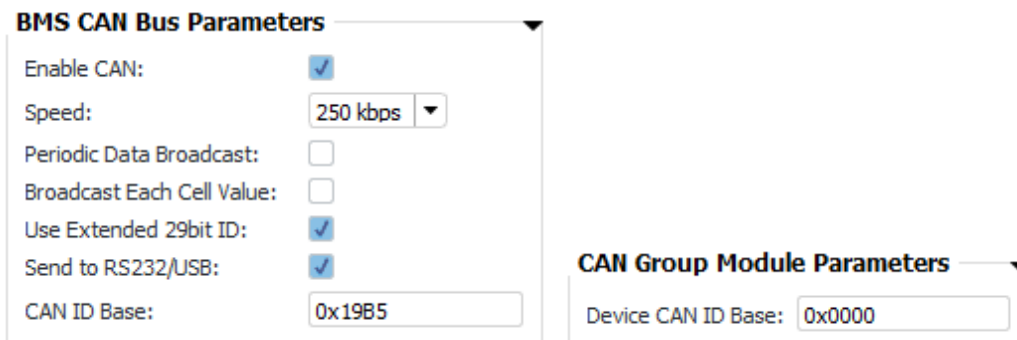

Figure 5.1: Data Transmission to Display parameters

5.1.2 CAN

CAN communication parameters are located in "BMS CAN Bus Parameters" and "CAN Group Module Parameters" boxes.



(a) BMS CAN Bus Parameters

(b) CAN Group Module Parameters

Figure 5.2: CAN communication parameters

- Enable CAN – Check to use EMUS G1 Control Unit CAN interface for data transmission and reception. BMS reset is required for change to take effect;
- Speed – EMUS G1 Control Unit CAN interface speed. Available speed values: 50, 125, 250, 500, 800, 1000 kbps. BMS reset is required for change to take effect;
- Periodic Data Broadcast – Check to enable periodic BMS status data broadcast over CAN bus. This broadcast uses data transmission to display periods;
- Broadcast Each Cell Value – Check to enable periodic broadcast of each cell values over CAN bus. This broadcast uses data transmission to display periods;
- Use Extended 29bit ID – Check to use extended 29 bit instead of basic 11 bit length CAN IDs. This setting does not affect format of charger CAN messages;

- Send to RS232/USB – Check to enable the transmission of received CAN messages to the corresponding serial interface as "CN1..." sentences. This function is not intended to be fully functional CAN/Serial converter, because of BMS CAN message processing and serial interface speed limitations. It is recommended to use when there are not many messages on the CAN network;
- CAN ID base – CAN ID Base address which allows to set an arbitrary base address for periodic broadcast of CAN messages generated by EMUS G1 Control Unit. It allows to use several EMUS G1 BMS systems on the same CAN bus or resolve the possible addressing conflicts with other devices. For extended 29 bit ID it represents upper 13 bits. For example the default extended ID 6581 is 19B5h in hexadecimal and BMS broadcast the messages starting from 19B50000h and so on. For basic 11 bit ID this is a base address number which must be added to the IDs of broadcasted messages. For example if this number is entered 800 then BMS will broadcast messages with standard 11 bit IDs starting from 800.
- Device CAN ID Base – CAN Identifier base, allocated for communication with EMUS G1 BMS internal peripherals. For extended 29 bit ID it represents upper 13 bit and for basic 11 bit ID is a base address number.

5.1.3 Cell communication

Cell communication settings are located in "Cell Communication Parameters" box. There are two options for serial communication type:

- Serial
- CAN

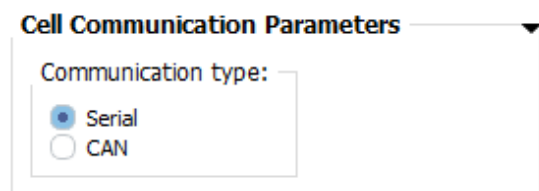

Figure 5.3: Cell communication parameters

5.2 CAN Cell Group Module configuration

CAN Cell Group Module (CGM) configuration is performed in Control Panel, Configuration page → CAN Devices tab.

Configuration is initiated by clicking on **Discover devices**, which discovers all available CAN Group Modules connected to EMUS G1 Control Unit CAN bus. Discovered devices appear in the Unconfigured list table (Figure 5.4) along with serial number and number of cells. When discovering CAN devices EMUS G1 Control Unit is put into configuration mode until the discovery is complete. During this mode, normal operation of the Control Unit is stopped. After discovery of devices, in order to assign particular CGM to a cell string, simply drag entry from Unconfigured list to Configuration (Figure 5.5) table and drop on the desired field.

Unconfigured List	
Serial	Cell Count
197	20
200	20
199	20
201	20
202	20
210	20

Figure 5.4: CAN Devices in unconfigured list

This table consists of columns that represent strings of series-connected cells that are connected in parallel and of rows that represent CAN Group Modules in a single cell string. E.g. if the battery pack consists of three strings connected in parallel, each one of them having 40 cells connected to two CAN Group Modules, then configuration table will be three columns and two rows. After placement of CAN Group Modules in each field  icon will appear. The column headers will be updated and will additionally display the total cell count of the string.

By pressing **Commit configuration** button finished configuration will be send to Control Unit and if everything is okay, the yellow "question mark" icons will turn to  icons, indicating that CAN Cell

Configuration

Parallel: 3

	String 0 (Cells: 40)	String 1 (Cells: 40)	String 2 (Cells: 40)
1	🔍 CGM sn: 197, cells: 20	🔍 CGM sn: 200, cells: 20	🔍 CGM sn: 202, cells: 20
2	🔍 CGM sn: 199, cells: 20	🔍 CGM sn: 201, cells: 20	🔍 CGM sn: 210, cells: 20
3			

Figure 5.5: CAN Devices in configuration table before commit

Configuration

Parallel: 3

	String 0 (Cells: 40)	String 1 (Cells: 40)	String 2 (Cells: 40)
1	✅ CGM sn: 197, cells: 20	✅ CGM sn: 200, cells: 20	✅ CGM sn: 202, cells: 20
2	✅ CGM sn: 199, cells: 20	✅ CGM sn: 201, cells: 20	✅ CGM sn: 210, cells: 20
3			

Figure 5.6: CAN Devices in configuration table after commit

Group Module configuration was completed successfully. If some error occurred while committing the configuration, some of the 🔍 icons may turn to ❌ icons, indicating an error.

Configuration

Parallel: 3

	String 0 (Cells: 40)	String 1 (Cells: 40)	String 2 (Cells: 40)
1	✅ CGM sn: 197, cells: 20	✅ CGM sn: 200, cells: 20	❌ CGM sn: 202, cells: 20
2	✅ CGM sn: 199, cells: 20	❌ CGM sn: 201, cells: 20	✅ CGM sn: 210, cells: 20
3			

Figure 5.7: CAN Devices in configuration table after commit failed

NOTE. If the CAN Group Modules were installed following the order that is suggested in the Installation section, it is advised to set up the configuration in such way that serial numbers of the CAN Group Modules would be sorted in a downwards ascending order in every column, and also from column to column (Figure 5.6). This way cells in Status page → Cells tab will be displayed correctly. Cell of the most negative potential (the one connected to the minus terminal) in the string will be displayed as the first cell on the left, and cell with of the most positive potential (the one connected to the plus terminal) will be the first one on the right.

5.3 Charging process

Configuration parameters related to the charging process are located in the Control Panel → Configuration page → Charging tab. Depending on their purpose, they are divided into "Charger

Parameters", "Charging Stage Duration Parameters" and "Cell Charging Parameters" group boxes. Parameters belonging to the "Charger Parameters" group box are the following:

- Number of Chargers;
- CAN Base ID;
- Min PWM Output;
- Max PWM Output.

Number of Chargers parameter appears only when the Control Panel is connected to a Control Unit that is uploaded with a firmware that supports a CAN charger, and should be set to a value that is equal to the actual number of parallel-connected chargers used in the system (possible values range from 1 to 16). Similarly the CAN Base ID parameter will appear only when the Control Panel is connected to a Control Unit that is uploaded with a firmware that supports Eltek Valere EV Power chargers. It should be set equal to "CAN base identifier" setting in the configuration of the charger itself, thus its possible values range from 0x0000 to 0x07FF. The Min PWM Output and Max PWM Output parameters will appear only when the Control Panel is connected to a Control Unit that is uploaded with a firmware that supports an analog signal controlled charging devices. Min PWM Output parameter should be set in such way that when the control signal level is equal to it, the output current of the charging device would be 0A; Likewise, Max PWM Output should be set in such way that the charging device would output the desired maximum current when the control signal is equal to it. The possible values of these two parameters range from 0.0V to 5.0V. Parameters in the "Charging Stage Duration Parameters" group box are the following:

- Max Pre-charge Stage Duration;
- Max Main Charge Stage Duration;
- Max Balancing Stage Duration.

The duration of any charging stage usually varies depending on the cell capacity, charging current, and many other aspects of system in which the battery is operated, therefore these parameters are recommended to be set in such way that their values would be about 1.5 times higher than the average duration of the corresponding charging stage, which should be determined experimentally. Alternatively, if actually the duration of the corresponding charging stages may expand indefinitely due to limited availability of power (e.g. in solar energy storage applications), these parameters can be set to 0 to turn off the corresponding charging stage duration checking. The possible values of these parameters range from 0 to 65 000 minutes. The column of cell voltage related settings on the left side of the "Cell Charging Parameters" group box consists of the following parameters:

- Fully Charged Voltage;
- Allowed Disbalance;
- Early Balancing Threshold;
- Charge restart voltage;
- Pre-charge Threshold.

The value of Pre-charge Threshold parameter is recommended to be set to discharge cut-off voltage value that is defined in the manufacturer provided specification sheet of the cells used in the battery pack (usually around 2.5 V for LiFePO4 chemistry cells). The optimal values of Charge Restart

Voltage, Early Balancing Threshold, and Allowed Disbalance parameters will vary depending on the way the battery is operated in particular application and are best to be determined experimentally, however there are certain guidelines that should be followed:

- The Allowed Disbalance parameter is recommended to be set to around 0.03 V for a good compromise between the balancing accuracy and the duration of the Balancing stage.
- In order to avoid trickle charging the battery, which can potentially decrease its lifetime, it is not recommended to set the Charge Restart Voltage parameter value above the nominal cell voltage that is defined in the cell specification sheet.
- The early balancing algorithm will have the biggest effect if the value of Early Balancing Threshold parameter is set below the nominal cell voltage that is defined in the cell specification sheet, since in such case it will take place both before the cell voltages reach the flat region of the charge curve, and after they rise above it.

The value of the Fully Charged Voltage parameter should be set to the charge voltage value that is defined in the cell specification sheet (not to be confused with charge cut-off voltage, which usually specifies the threshold above which the operation is not safe). Usually this value is around 3.65 V for LiFePo4 chemistry cells. The range of possible values is from 2.00 V to 4.55 V for all of these parameter except the Allowed Disbalance - possible values for this parameter ranges from 0.00 V to 0.20 V. The charging current related settings on the right side of the "Cell Charging Parameter" group box consist of the following parameters:

- Fast Charging Current;
- Slow Charging Current;
- Pre-charge Current;
- Charging Finished Current.

Fast Charging Current parameter can be set to any desired value as long as it does not exceed the manufacturer specified maximum output current of the used CAN charger. The Slow Charging Current parameter allows to charge with reduced charging current in case the available grid power is limited, and should therefore be set accordingly lower than the Fast Charging Current parameter. The possible values of these two parameters range from 0.1A to 1000 A. Pre-charge Current and Charge Finished Current parameters are expressed as percentage either from 1C current or maximum charging current depending on whether the firmware of the connected Control Unit supports a CAN charger or an analog signal controlled charging device. The resulting absolute value will therefore depend on the Capacity parameter or charging device's output current when the control signal level is equal to Max PWM Output parameter accordingly. Pre-charge Current is recommended to be set in such way that the resulting absolute value would be around $\frac{1}{10}$ of the current during Main Charging Stage. Charging Finished Current is recommended to be set below maximum balancing current, which depends on the Maximum Balancing Rate parameter, as well as the model of Cell Modules used in the battery pack. The range of possible values for these two parameters is from 0.1 % to 25.5 %.

5.4 Protections

Settings that regulate the behavior of the "PF12 Battery Contactor Output" pin function can be found in the Configuration page → Battery Pack tab → Protection group box, and consist of ten sets of parameters for each different protection type. Each set contains up to five of the following parameters:

- Enable/disable checkbox (with the corresponding protection type label next to it);
- "Activate at" threshold (if applicable to corresponding protection type);
- "Deactivate at" threshold (if applicable to corresponding protection type);
- Act. delay (activation delay);
- Deact. delay (deactivation delay).

No Cell Communication protection is an exception and also has the Cell Comm Restore enable/disable checkbox and Restore duration parameter in its set. The "Activate at" thresholds of the Cell Under-Voltage and Cell Over-Voltage protections are recommended to be set respectively to discharge cut-off voltage and charge cut-off voltage values that are defined in the manufacturer provided specification sheet of the cells used in the battery pack. The optimal value for the same parameter of the Cell Module Over-Heat protection is around 60 °C regardless of the model of Cell Modules used. The optimal values of the rest of these parameters, as well as The necessity of each type of protection should be assessed according to the design and requirements of the system in which EMUS G1 Control Unit is used, or determined experimentally.

Similarly to the power reductions, the possible value range for the "Activate at" and "Deactivate at" threshold parameters depend on the corresponding protection type:

- For Cell Under-Voltage and Cell Over-Voltage protections both parameters can have a value from 2.00 to 4.55V;
- For Discharge Over-Current and Charge Over-Current protection the range of possible values of the "Activate at" threshold parameter is from 0.1 to 1600.0A;
- For Cell Module Over-Heat and Cell Over-Heat protections both parameters can have a value from 20 to 155°C.

The possible value range for the Act. delay and Deact. delay parameters is 0.0 to 25.5s and 0 to 255s respectively, regardless of the protection type.

5.5 Load power reductions

Settings that regulate the behavior of the "PF16 Power Reduction Output" pin function can be found in the Configuration page → Battery Pack tab → Power Reductions group box, and consist of four sets of parameters for each different power reduction type. Each set contains up to five of the following parameters:

- Enable/disable checkbox (with the corresponding power reduction type label next to it);
- "Activate at" threshold;
- "Deactivate at" threshold (if applicable to power reduction type);
- Act. delay (activation delay);
- Deact. delay (deactivation delay).

The screenshot shows a configuration window titled "Reduction" with a dropdown arrow on the right. Inside the window, the label "High Cell Module Temperature:" is followed by a checked checkbox. To the right of the checkbox are two rows of parameters: "Activate at: 50 °C Act. delay: 0.0 s" and "Deactivate at: 50 °C Deact. delay: 0 s". Each numerical value is in a small input field.

Figure 5.8: Single reduction example

The "PF16 Power Reduction Output" pin function can be used for various different purposes and the optimal values of these parameters will vary accordingly, therefore they are best to be determined experimentally. The possible value range for the "Activate at" and "Deactivate at" threshold parameters depend on the corresponding power reduction type:

- For Low Cell Voltage power reduction both parameters can have a value from 2.00 to 4.55V;
- For High Discharge Current power reduction the range of possible values of the "Activate at" threshold parameter is from 0.1 to 1600.0 A;
- For High Cell Module Temperature and High Cell Temperature power reduction the both parameters can have a value from 20 to 155 °C; The possible value range for the Act. delay and Deact. delay parameter is 0.0 to 25.5 s and 0 to 255 s respectively, regardless of the power reduction type.

5.6 Current measurement

Current measurement configuration is performed in Control Panel → Configuration → SOC → Current sensor box. There are 6 related configuration parameters:

- Sensor Type
- L Calibration Value
- H Calibration Value
- Deadzone
- Reverse Direction
- Measurement zero offset

Fields of L and H calibration values are intended to be filled with calibration values which are written on the EMUS G1 Current Sensor case. L calibration value is used to adjust measurements for low currents and H calibration value is used to adjust measurements for high currents. Deadzone field is used to improve zero value stability, meaning that current values that are within set range both negative and positive are all treated as 0. Reverse direction option allows to reverse measurement polarity. It is required to use this option to ensure that positive current is displayed during charging and negative when discharging. After installation it is recommended to check that displayed current measurement value is equal to 0. If not current measurement should be reset by clicking on **Reset Current to 0** button. This procedure automatically determines the value of Measurement Zero Offset parameter, thus compensating any offset that occurs due to surrounding stray magnetic fields or other environment factors.

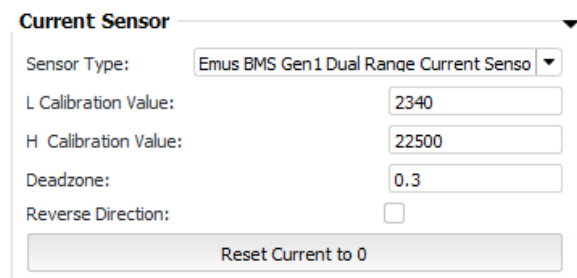

Figure 5.9: Current measurement parameters

5.7 SOC estimation

Apart from being dependent on current measurement parameters, State of Charge estimation is also related to the following parameters:

1. "Capacity", which can be found in the Control Panel → Configuration page → Battery Pack tab → Battery Pack Box;

2. "Reduce SOC at Under-Voltage", which can be found in the Control Panel → Configuration page → SOC tab → State of Charge (SoC) parameters;
3. "SOC at Low Volt. Warn.", which can be found in the Control Panel → Configuration page → SOC tab → State of Charge (SoC) parameters;

The "Capacity" parameter value is used as a reference in SOC estimation, and should be set to nominal capacity of a single cell specified by the manufacturer, unless EMUS G1 Control Unit is configured to use different than nominal capacity during the discharge cycle, e.g. 80 % or 110 % of the nominal capacity. In such case the value of the "Capacity" parameter should also be set to 80 % or 110 % respectively, so that the State of Charge value at the end of a discharge cycle would be 0 %. The range of possible "Capacity" parameter values is from 0.1 Ah to 1600 Ah.

If it is necessary to use the "Reduce SOC at Under-Voltage" feature the corresponding checkbox should be checked, and "SOC at Low Volt. Warn." value should be set to whatever State of Charge value the Low Voltage Reduction "Activate at" parameter value corresponds to. This can be determined from the 0.5 C discharge curve in the manufacturer provided cell specification sheet. The range of possible "SOC at Low Volt. Warn." parameter values is from 0 % to 100 %.

5.8 Heater control

Figure 5.11: State of Charge parameters

Settings for heater can be found in Control Panel, Configuration page → Battery Pack tab → Heater and Fan Control.

- "Minimum Charging Temperature" parameter is used in pre-heating charging stage, it determines temperature threshold below which heater is activated until this value is reached. It can be disabled by entering value of -100 .
- "Normal Temperature" parameter is used when Climate Control is enabled and charger is disconnected. External heater is activated until temperature of cell batteries reaches this value;
- "Charging Temperature" parameter is used when Climate Control is enabled and charger is connected. External heater is activated until temperature of cell batteries reaches this value.
- "Minimum SOC" parameter determines SoC threshold below which Climate Control is disabled in order to prevent deep discharge.

Figure 5.10: "Capacity" parameter box

Figure 5.12: Heater and Fan parameters

- "Max duration when not charging" parameter refers to time duration after which Climate Control is disabled when charger is not connected. Setting this parameter to zero will turn off the corresponding safety mechanism that disables the Climate Control.

5.9 Cooling fan control

Settings for cooling fan can be found in Control Panel, Configuration page → Battery Pack tab → Heater and Fan Control. Parameter "Fan On Temperature" determines temperature threshold when Fan is activated.

5.10 DC/DC converter control

DC/DC Converter control settings are located in the Control Panel, Configuration page → Battery Pack tab → DC/DC Converter control box and consists of two parameters:

- "Active State Threshold", that is used when ignition input is in logic high state or when charger is connected;
- "Passive State Threshold", that is used when ignition input is in logic low state and charger is not connected.



Figure 5.13: DC/DC Converter Control parameters

Each threshold field accepts values from 2.00 V to 4.55 V.

5.11 Pin mapping

Pin mapping settings are located in Control Panel, Configuration page → Pin Mapping tab and consist of a list of parameter groups for each re-mappable Control Unit's pin. Each group contains two parameters:

- Assigned Pin Function – determines the pin function of that particular pin;
- Invert – has different meaning depending on the pin function and whether the pin is general or special purpose.

The set of possible "Assigned Pin Function" parameter values for each pin can be seen by clicking on the corresponding drop-down menu. It differs depending on whether the pin is input or output, also whether it is a general or special purpose pin. The default function of a particular pin is always a top entry in the drop-down list.

The meaning of the "Invert" parameter for general purpose inputs, outputs and "SOC OUT" pin is self explanatory – it determines which logic level corresponds to the active state of the signal. There are some exceptions for special purpose inputs:

- For current sensor inputs (INPUT1, INPUT2, INPUT3, INPUT4), if they are mapped with their default pin function, the "Invert" parameter has no effect. Otherwise the meaning is the same as for general purpose inputs;

Pin Name	Assigned Pin Function	Invert
INPUT 1:	PF14 Current Sensor Input	<input type="checkbox"/>
INPUT 2:	PF14 Current Sensor Input	<input type="checkbox"/>
INPUT 3:	PF14 Current Sensor Input	<input type="checkbox"/>
INPUT 4:	PF14 Current Sensor Input	<input type="checkbox"/>
AC SENSE:	PF3 Charger Mains AC Sense Input	<input type="checkbox"/>
IGN. IN:	PF4 Ignition Key Input	<input type="checkbox"/>
FAST CHG.:	PF2 Fast Charge Switch Input	<input type="checkbox"/>

- For speed sensor input (SPEED IN), if it is mapped with its default pin function, the "Invert" parameter changes which edge is used to count the pulses of the speed signal – if not inverted on rising edge, if inverted on falling edge. Otherwise the meaning is the same as for general purpose inputs.

Additional parameters that regulate the minimum and maximum duty cycle values of the PWM signal when the "SOC OUT" pin is mapped with "PF11 State of Charge Output" function can be found in Configuration page → SOC tab → SOC OUT Signal Parameters box. Likewise, similar parameters related to the "PF18 Analog Charger Control Output" function can be found in Configuration page → Charger tab → Analog Charger Parameter box. The necessity of each pin function, as well as the values of the corresponding "Invert" and addition parameters should be assessed and determined according to the design and requirements of the system in which EMUS G1 Control Unit is used.

5.12 Display Unit

Display Unit settings are located in Control Panel, in the top menu bar, External devices" menu → Display entry. There are four configurable parameters:

- "Contrast" – changes display contrast from 0 to 100 %;
- "Sleep after" – when specified time duration value elapses, during which no actions are taken, devices goes to sleep;
- "Temperature units" – determines whether temperature is displayed in Celsius or Fahrenheit;
- "Display mode" – allows to choose between "Electric vehicle" or "Energy storage" display modes.

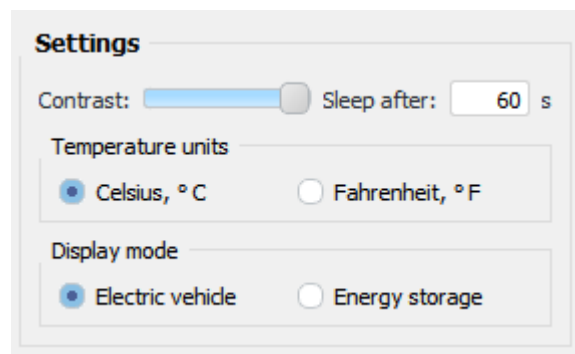

Figure 5.15: Display Unit settings in Control Panel

6 Maintenance

This section contains information and step-by-step guides on how to perform certain EMUS G1 BMS maintenance operations. These operations cover measurement calibration, firmware updates, security routines, etc. Most of them need to be performed only once.

All maintenance procedures are performed mainly using EMUS G1 Control Panel which can be downloaded from our website <https://emusbms.com/support>.

6.1 Calibration of Cell Module temperature sensors

The procedure to calibrate the internal temperature sensor of Cell Modules is the following:

1. Open Control Panel and navigate to Configuration → Battery Pack tab → Battery Pack box.
2. Click on button.
3. In the opened window enter new temperature value which should be measured by a calibrated external tool and will be used as a reference temperature.
4. Click to finish calibration.

The procedure to calibrate the external temperature sensor of Cell Modules is the following:

1. First step is the same as internal temperature calibration.
2. Click on button. A window showed in Figure 1 should appear.
3. Before adjustments, click on button in order to discard any changes. Curve in pink color is the original thermistor curve and curve in teal is modifiable one.
4. Enter temperature related resistance values of selected thermistor. It is done by clicking on button and filling the values in. Once done or button must be pressed. To return to default values button should be pressed.
5. Adjust position of the modified curve by Coefficient handles if necessary. By sliding β , γ and δ handles adapt teal curve to the pink one to get the best calibration results.
6. Once adaption is finished it is possible to transfer calibration values to particular Cell Module or to all of them together. Select which Cell Modules should be calibrated: to send values to one particular module a cell ID should be entered to "Module ID" field, to send values to all Cell Modules at once "Select all" check-box should be selected.
7. Lastly button should be pressed and new calibration values will be uploaded to selected Cell Modules.

It is important to notice that, external temperature calibration should be performed only when the type of the thermistors used is different than the type of the thermistors provided by EMUS, UAB. Otherwise the default calibration values are valid and there is no need for calibration.

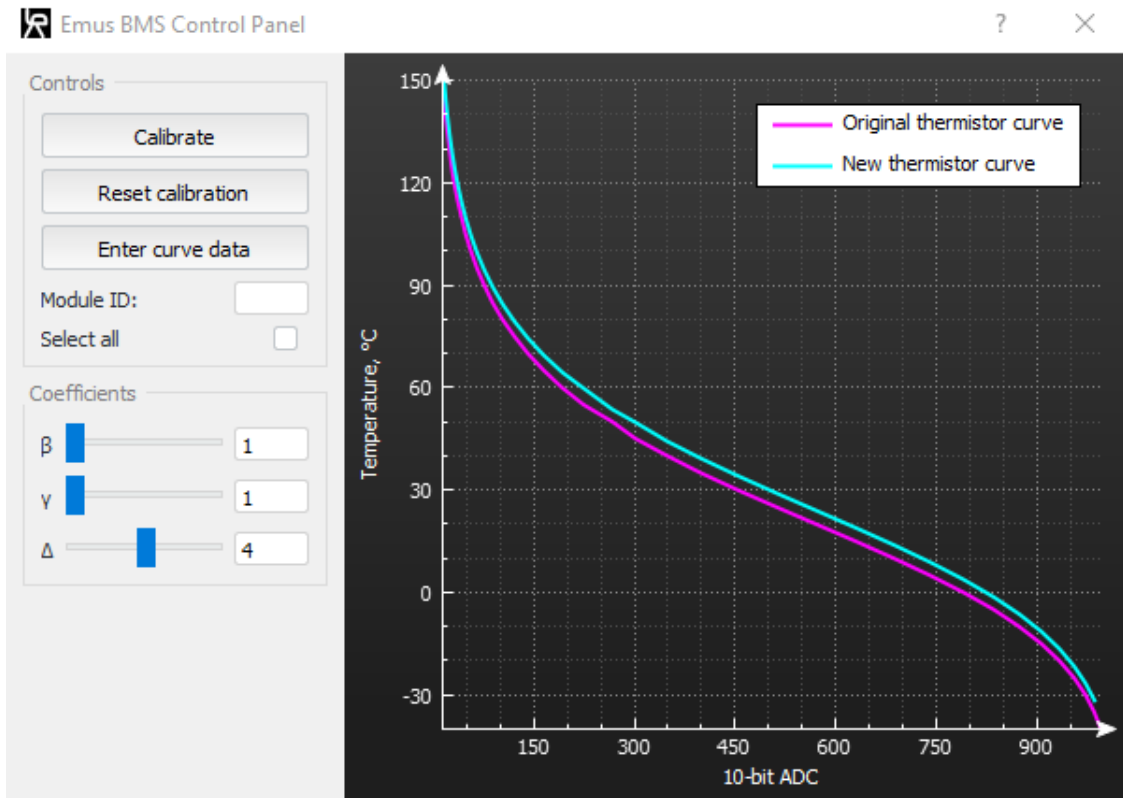

Figure 6.1: External temperature sensor calibration window

6.2 Re-calibration of current sensor

Occasionally, due to the influence of various environment factors, EMUS G1 Current Sensor factory calibration values become invalid and it start to measure the current inaccurately. This results in several undesired effects, most notably inaccurate SOC estimation. In such cases it is necessary to re-calibrate the current sensor by manually determining new calibration values

Calibration of current sensor is performed in Control Panel → Configuration page → SOC tab → Current sensor box. There are main 2 fields involved in sensor recalibration: L Calibration value and H calibration value. This procedure will require an external current measurement device (e.g. current clamp), and for the best results should be done without removing the current sensor from the system. The rest of it is described in the following steps:

1. Write down current L and H calibration values.
2. Produce a constant, stable current of 30 A to 70 A in the system (e.g. connect a charger).
3. Measure the current with the external current measurement device and write it down. Also write down the value measured by EMUS G1 Control Unit - it can be found in Control Panel → Status page → General tab → Battery Pack box.
4. Calculate the new value of "L Calibration Value" parameter using (1) equation.
5. Produce a constant, stable current of 130 A and repeat steps 3 and 4 to determine the new value of "H Calibration Value" parameter.

The following equation is used to recalculate both L and H calibration values:

$$C_{new} = C_{current} * \frac{I_{set}}{I_{measured}} \quad (1)$$

where C_{new} is new calculated calibration value, $C_{current}$ - current calibration value, I_{set} - current set for power supply, $I_{measured}$ - measured current by Control Unit.

6.3 Master Clear

Master clear can also be described as factory reset feature. It is used when there is a need to reset the BMS configuration to default values and clear the statistics, events and password. This excludes "Master clear count" statistic.

Master clear procedure can be done using either RS232 or USB interface to connect the Control Unit to a computer. Before performing this procedure it is recommended to disable the Broadcast on RS232/USB" feature in the Control Panel, → Configuration page → General tab. This way the periodically broadcasted data will not hinder the procedure progress observation. The mentioned feature can be re-enabled after the procedure is done. The procedure itself comprises the following steps:

- Acquire a third-party terminal emulator software that is capable of connecting to COM ports (e.g. RealTerm, TeraTerm, PuTTY, etc.)
- Connect Control Unit to computer using USB or COM connector.
- Connect to EMUS G1 Control Unit COM port via the terminal emulator
You can find it in Device Manager window under Ports (COM & LPT) option. Name of this COM port should be "USB Serial Port (COMx)", where x is the number, which digit count can be more than 1.
- Toggle power supply to Control Unit in order to reset it. EMUS G1 Control Unit should respond with "VR1" sentence, meaning operation succeeded.
- Within 10 seconds of BMS startup you must enter "xxxxx" characters without "" and hit enter. EMUS G1 Control Unit will again respond with "VR1" sentence, meaning master clear operation succeeded.

6.4 Setting up password

As a security feature, EMUS G1 Control Unit allows to prevent unqualified users from performing maintenance operation and from changing its configuration parameters by means of two separate passwords. This gives three different levels of access:

- Level 2 access allows to change individual configuration parameters and perform all maintenance operations;
- Level 1 access allows most maintenance operations, such as firmware updates, loading configuration from a file, resetting configuration to defaults, clearing the events log and statistics, resetting current measurement to 0, resetting the Control Unit, setting the SOC value, and calibrating the internal and external temperatures sensors of the cell modules, but does not allow changing individual configuration parameters;
- level 0 access only allows BMS activity monitoring and saving configuration to a file, but no maintenance other operations or changes to the configuration;

The procedure to set the passwords is the following:

1. Open Control Panel and select Configuration → Management tab;
2. Click inside Security box, and type in a matching string of 4 to 8 "ASCII" symbols into the two resulting dialog windows to set the level 2 password;
3. Press to log out into level 1 access;
4. Click to set level 1 password.

Pressing will log the system out into a lower access level. If there is a need to remove a password, it can be done by performing the following steps:

1. Log into a desired access level by clicking on and entering the corresponding password;
2. Click button and press twice, leaving password field empty to clear the password of that level.

It is important to note that entering a password incorrectly for 10 times in a row will disable login access for 10 minutes in order to prevent brute force attacks. Also, it should be noted that when saving the password into a file together with the configuration it is stored in plain text.

6.5 Exporting and importing configuration

EMUS G1 Control Unit features configuration management that provides functionality to save and load system configuration file. All EMUS G1 Control Unit configurable parameters are stored inside this file. It is possible to save system password in the same file too, but it will be saved without encryption.

Management options are located in Control Panel → Configuration page → Configuration box. In order to save current BMS configuration click on button and proceed to following pop-up window. Configuration file will be saved in .bcf format. In order to upload the configuration to the system from a previously saved EMUS G1 Control Unit configuration file and want to upload it to the system click on button. Immediately new window will pop-up with progress bar showing uploading status.

6.6 Control Unit firmware update

In order to ensure that EMUS G1 Control Unit would have all the latest features and bug-fixes, it is recommended to periodically perform Control Unit firmware update procedure. The latest firmware images can be found online at <https://emusbms.com/support>, however this procedure also to revert back to an older firmware if necessary.

NOTE: Beware, there are few firmware images with the same version, but they differ in supported charger type.

These steps will guide you through firmware upgrade process:

1. Open Control Panel and select Update → Control Unit tab.
2. Click on button.
3. In opened dialog select desired EMUS G1 Control Unit firmware file with extension .img.
4. Click on button to initialize update procedure.

File, Version and SN fields will be updated with information from image file if it is valid.

After pressing the button all configuration parameters and statistics values are temporarily saved in local hard drive and memory of the Control Unit where they resided is formatted. After update configuration and statistics stored on hard drive are transferred back to Control Unit. This is done in order to make sure that new firmware would function flawlessly.

6.7 CAN Cell Group Module firmware update

CAN Cell Group Module Firmware update procedure is similar to Control Unit update. Latest firmware can be found on our website <https://emusbms.com/support>.

These steps will guide you through firmware upgrade process:

1. Connect device to the same CAN bus to which Control Unit is connected.
2. Open Control Panel and select Update → CAN Devices tab.
3. Click on button to discover all available devices on CAN bus.
4. In the table below select desired CAN Cell Group Module which firmware should be updated.
5. Click on button and select firmware file. If file is valid then File, Version and Target Device fields will be updated with corresponding information from the file.
6. Press button to initialize update progress. A progress bar will appear under this button with the status field, where process information will be shown. During update process normal operation of control unit will be stopped.

6.8 Display Unit firmware update

Latest firmware for Display Unit can be found on our website <https://emusbms.com/support>.

These steps will guide you through firmware upgrade process:

1. Open Control Panel, in the top menu bar, under "External devices" select Display entry;
2. Click on button.
3. In the resulting dialog select EMUS G1 Display Unit firmware file with extension .img.
4. Click on button to initialize update procedure.

Firmware version and Serial number fields will be updated with information from image file if it is valid.

6.9 Exporting and importing statistics

Both Export and Import options can be reached from top menu bar "Options" option. By clicking on "Export statistics" Control Panel saves all statistics of currently connected Control Unit to local hard drive. In order to import them, "Import statistics" should be selected. There is no need to specify path to save them, because Control Panel does it by itself. These actions with statistics can only be done when logged-in and no charging or firmware update operation is taking place.

It is possible to export statistics from one Control Unit and import them into another. This is useful when Control Unit needs to be replaced and data must be preserved

6.10 Changing language of the Control Panel

Control Panel comes in four different languages:

- German
- English

- Italian
- Russian

To change language click on Language menu in the top bar and select one from the drop-down list. Control Panel restart is required so that new language could take effect.

7 Technical information

7.1 Control Unit

7.1.1 Mechanical specification

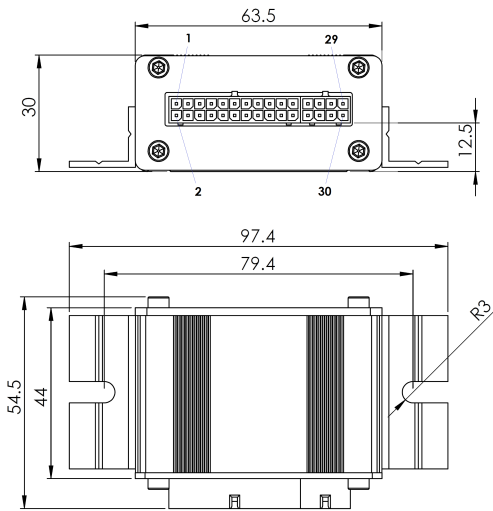

Figure 7.1: EMUS G1 Control Unit mechanical drawing (applies both to CU010D and CU020E models). All dimensions in millimeters.

Table 7.1: EMUS G1 Control Unit connector pin assignment

Pin No.	Assignment		Mating Housing	Terminal
	CU010D	CU020E		
1	+12V	+24V	TE Connectivity 2-794617-2 or equivalent	TE Connectivity 794610-1 (recommended crimp tool TE Connectivity 91501-1)
2	GROUND			
3	CELL RX+			
4	CELL RX-			
5	CELL TX+			
6	CELL TX-			
7	USB PWR			
8	GROUND			
9	USB D+			
10	USB D-			
11	DISP.TX			
12	DISP.RX			
13	HEATER			
14	BAT.LOW			
15	BUZZER			
16	CHG.IND.			
17	CHARGER			
18	FAST CHG.			
19	IGN.IN			
20	AC SENSE			
21	CAN+			
22	CAN-			
23	SPEED IN			
24	SOC OUT			
25	+5V OUT			
26	GROUND			
27	INPUT 4			
28	INPUT 3			
29	INPUT 2			
30	INPUT 1			

7.1.2 Electrical characteristics

Table 7.2: EMUS G1 Control Unit electrical characteristics

Item	Conditions	Value	
		CU010D	CU020E
Operating voltage		8 to 16 VDC (12 VDC typical)	9 to 32 VDC (24 VDC typical)
Power supply reverse polarity protection		Yes	
Current consumption	At typical supply voltage, with nothing else connected	54 mA	20 mA
	At typical supply voltage, with Current Sensor connected	72 mA	25.5 mA
General purpose output max sinking current (resettable fuse trip current)		0.5 A	
General purpose output max voltage		16 VDC	32 VDC
General purpose input ON voltage		5 to 16 VDC	5 to 32 VDC
General purpose input OFF voltage		0 VDC	
Current sensor input ON voltage	Applies when pin is mapped with function other than PF14 Current Sensor Input	5 VDC	
Current sensor input OFF voltage		0 VDC	
SOC OUT output voltage range		0 to 5 VDC	
SOC OUT output resistance		1 k Ω	
SOC OUT output PWM signal frequency	Applies when pin is mapped with function PF11 State of Charge Output or function PF18 Analog Charger Control Output	7.8125 kHz	
SPEED IN input signal frequency range	Applies when SPEED IN input is mapped with function PF1 Speed Sensor Input	15 kHz	7kHz
SPEED IN input ON voltage		5 to 16 VDC	5 to 32 VDC
SPEED IN input OFF voltage		0 VDC	
USB interface controller		FT232R	
USB power supply data line transient/overvoltage protection		-	5 VDC
USB/RS232 interface galvanic isolation		None	
RS232 interface transceiver		ADM202E	
USB interface duplexity		Full duplex (send and receive)	
RS232 interface duplexity	USB not connected	Full duplex (send and receive)	
	USB connected	Half duplex (send only)	
USB/RS232 interface baud rate		57.6kbps	
USB/RS232 interface data bits		8 bits	
USB/RS232 interface parity		None	
USB/RS232 interface stop bits		1 bit	

USB/RS232 interface flow control		None	
CAN transceiver		MCP2551	
CAN Speed		50kbps, 125kbps, 250kbps, 500kbps, 800kbps, 1Mbps	
CAN data line transient/overvoltage protection		-	24 VDC

7.1.3 Other specifications

Table 7.3: EMUS G1 Control Unit other specifications

Item	Condition	Value
Max number of Cell Modules in cell communication daisy chain when using Top and Bottom Isolators		254
Max number of CAN Cell Group Modules on CAN bus		32
Operating temperature		-20 to +60°C
IP rating		IP54
Weight	With quick start kit	172 g
	Without quick start kit	94 g

7.2 Cell Module

7.2.1 Mechanical specification

7.2.1.1 A/B type

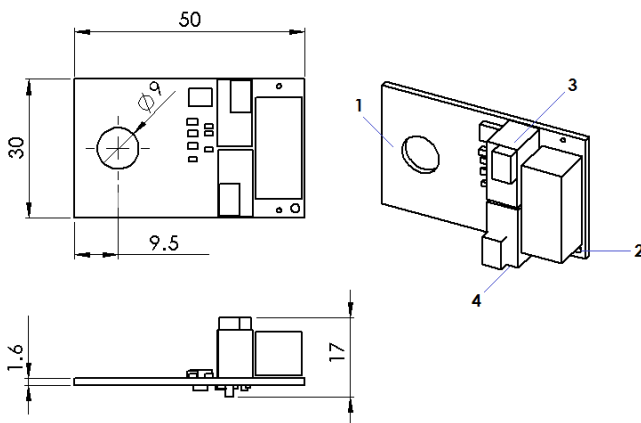

Table 7.4: EMUS G1 Cell Module A/B rev.E (CM010E) terminal assignment

Terminal No.	Assignment	
	CM010E A	CM010E B
1	CELL -	
2	CELL +	
3	UP	DN
4	DN	UP

Figure 7.2: EMUS G1 Cell Module A/B rev.E (CM010E) mechanical drawing. All dimensions in millimeters.

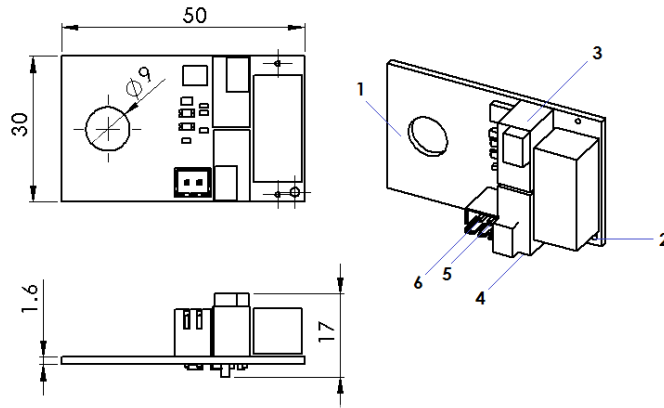

Figure 7.3: EMUS G1 Cell Module A/B rev.F (CM010F) mechanical drawing. All dimensions in millimeters.

Table 7.5: EMUS G1 Cell Module A/B rev.F (CM010F) terminal assignment

Terminal No.	Assignment		Mating housing	Terminal crimp
	CM010F A	CM010F B		
1	CELL –		-	-
2	CELL +			
3	UP	DN		
4	DN	UP		
5	External temperature sensor input		Weli Sheng P2-I25019	Weli Sheng I25019PS-2
6	External temperature sensor input			

7.2.1.2 Small type

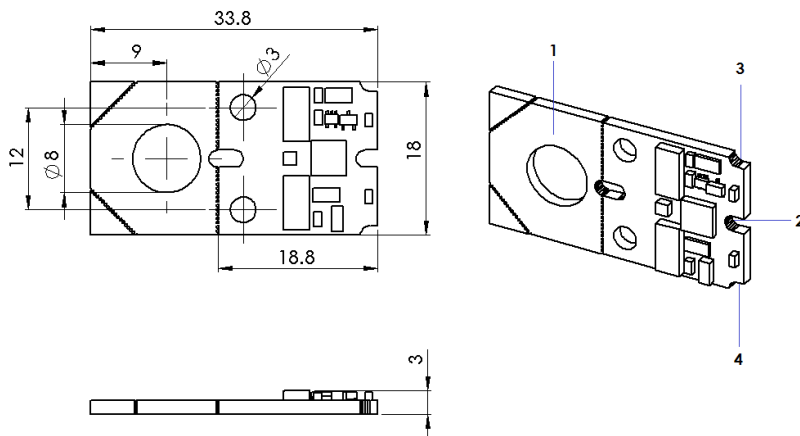

Table 7.6: EMUS G1 Cell Module Small (CM020C) terminal assignment

Terminal No.	Assignment
1	CELL –
2	CELL +
3	UP
4	DN

Figure 7.4: EMUS G1 Cell Module Small (CM020C) mechanical drawing. All dimensions in millimeters.

7.2.1.3 GBS type

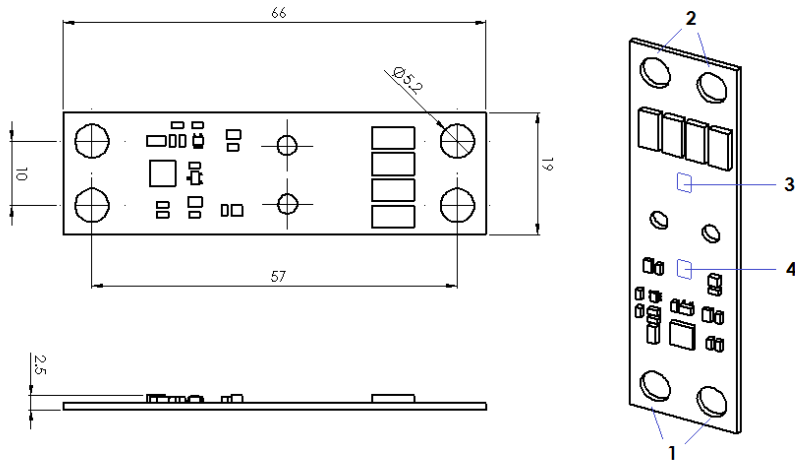

Table 7.7: EMUS G1 Cell Module GBS (CM030B) terminal assignment

Terminal No.	Assignment
1	CELL –
2	CELL +
3	UP
4	DN

Figure 7.5: EMUS G1 Cell Module GBS (CM030B) mechanical drawing. All dimensions in millimeters.

7.2.1.4 240Ah Type

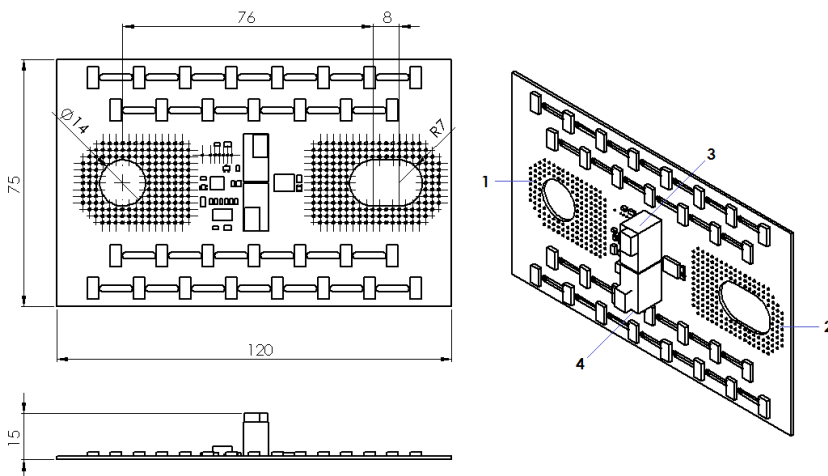

Table 7.8: EMUS G1 Cell Module 240Ah (CM040B) terminal assignment

Terminal No.	Assignment
1	CELL –
2	CELL +
3	UP
4	DN

Figure 7.6: EMUS G1 Cell Module 240Ah (CM040B) mechanical drawing. All dimensions in millimeters.

7.2.1.5 200-400Ah type

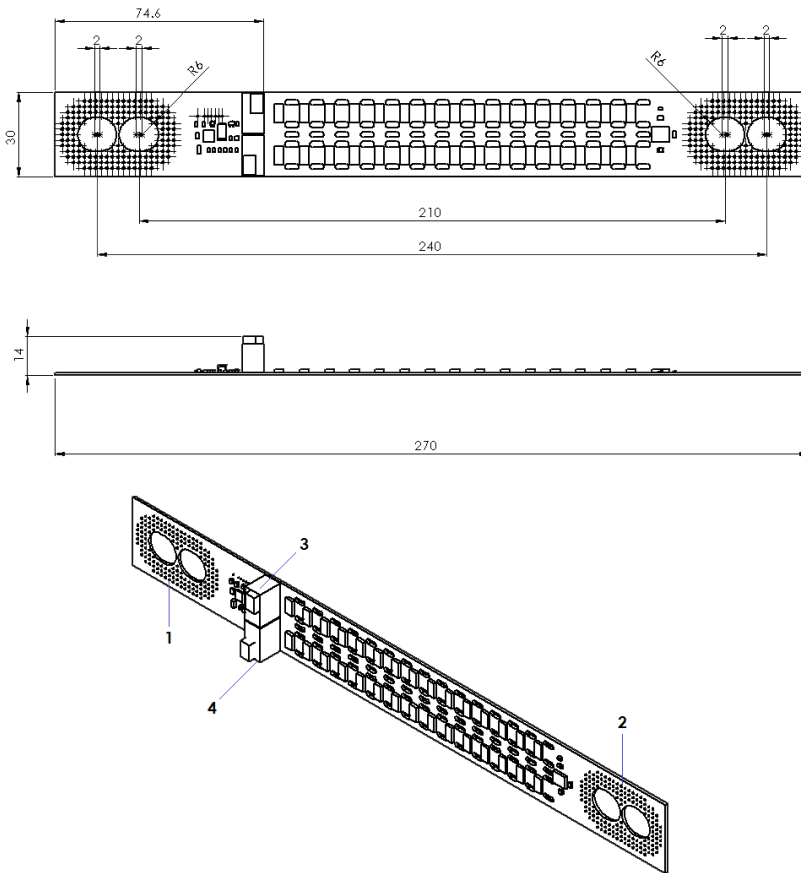

Table 7.9: EMUS G1 Cell Module 200-400Ah (CM050B) terminal assignment

Terminal No.	Assignment
1	CELL –
2	CELL +
3	UP
4	DN

Figure 7.7: EMUS G1 Control Module 200-400Ah (CM050B) mechanical drawing. All dimensions in millimeters.

7.2.1.6 CALB CAM 72Ah type

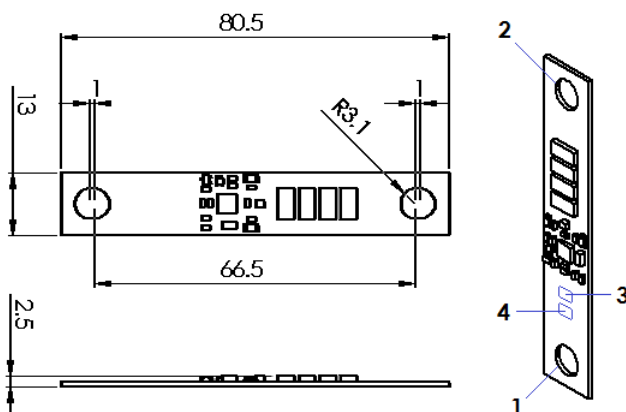

Table 7.10: EMUS G1 Cell Module CALB CAM 72Ah (CM060A) terminal assignment

Terminal No.	Assignment
1	–
2	+
3	UP
4	DN

Figure 7.8: EMUS G1 Cell Module CALB CAM 72Ah (CM060A) mechanical drawing. All dimensions in millimeters.

7.2.1.7 3A type

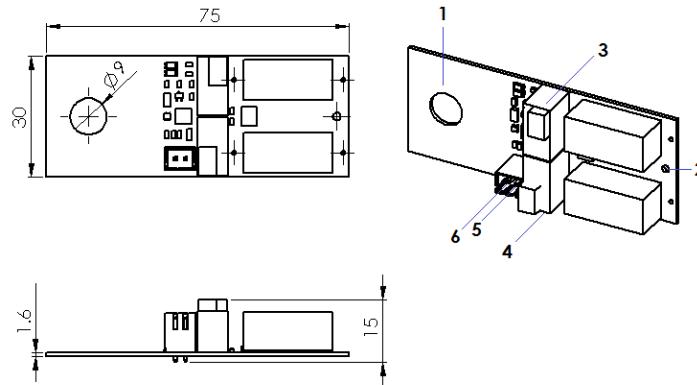

Figure 7.9: EMUS G1 Cell Module 3A (CM070A) mechanical drawing. All dimensions in millimeters.

Table 7.11: EMUS G1 Cell Module A/B rev.F (CM010F) terminal assignment

Terminal No.	Assignment		Mating housing	Terminal crimp
	CM010F A	CM010F B		
1	CELL –		-	-
2	CELL +			
3	UP	DN		
4	DN	UP		
5	External temperature sensor input		Weli Sheng P2-I25019	Weli Sheng I25019PS-2
6	External temperature sensor input			

7.2.2 Electrical characteristics

Table 7.12: EMUS G1 Cell Module electrical characteristics

Item	Value							
	CM010E	CM010F	CM020C	CM030B	CM040B	CM050B	CM060A	CM070A
Operating voltage	2.0 VDC to 4.55 VDC							
Voltage measuring range	2.0 VDC to 4.55 VDC							
Voltage measurement resolution	10 mV							
Voltage measurement accuracy	1.0 %			0.2 %		1.0 %	0.2 %	
Internal temperature measuring range	-99 °C to 154 °C							
Internal temperature measurement resolution	1 °C							
Internal temperature measurement accuracy	± 5 °C							
External temperature measuring range	-	-99 °C to 154 °C	-	-	-	-	-	-99 °C to 154 °C

External temperature measurement resolution	-	1 °C	-	-	-	-	-	1 °C
External temperature measurement accuracy	-	± 5 °C	-	-	-	-	-	± 5 °C
Current consumption in active mode, when communication LED is on, supply voltage = 3.60V	7.7 mA							
Current consumption in active mode, when communication LED is off, supply voltage = 3.60V	4.7 mA							
Current consumption in sleep mode, supply voltage = 3.60V	258 µA	278 µA	26.8 µA	25.0 µA	28.3 µA	28.0 µA	26.0 µA	274 µA
Balancing resistor resistance	2.70 Ω		4.10 Ω	2.05 Ω	0.80 Ω	0.80 Ω	3.00 Ω	1.35 Ω
Balancing resistor rated power	5 W		2 W	4 W	30 W	30 W	4 W	10 W

7.2.3 Other specifications

Table 7.13: EMUS G1 Cell Module other characteristics

Item	Value							
	CM010E	CM010F	CM020C	CM030B	CM040B	CM050B	CM060A	CM070A
Operating temperature	-30 to +85 °C	0 to +70 °C	-30 to +85 °C					
IP Rating	IP21							
Weight	15 g	16.5 g	6.3 g	6.2 g	38 g	33 g	5.4 g	24 g
CELL + wire length	0.1 m		-	-	-	-	-	0.1 m
CELL + wire ring terminal type	Molex 19323-0011 (recommended crimp tool Molex 64003-0100 or PRESSMASTER KWB0325S)							
Communication wire length	-	-	0.1 m	-	-	-	0.1 m	-
External temperature sensor type (applies to CM010F and CM010A only)	VISHAY NTCLE100E3104JB0							
Sleep mode timeout when not balancing	60 ms							
Sleep mode timeout when balancing	10 s							
Wakeup source	Cell communication signal edge, watchdog timer timeout (8 s period)							

7.3 Cell Communication Adapters

7.3.1 Mechanical specification

7.3.1.1 Top Isolator

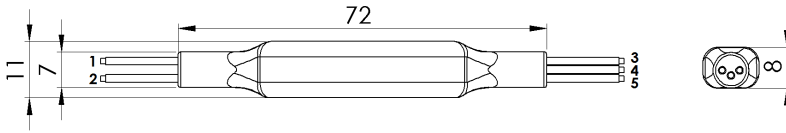

Figure 7.10: EMUS G1 Top Isolator (CCA010D) mechanical drawing. All dimensions in millimeters.

Table 7.14: EMUS G1 Top Isolator (CCA010D) wire assignment

Pin No.	Wire Color	Assignment
1	Black	GND
2	Brown	OUT
3	Black	TOP CELL –
4	Green	UP
5	Red	TOP CELL +

7.3.1.2 Bottom Isolator

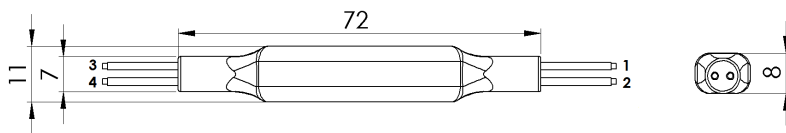

Figure 7.11: EMUS G1 Bottom Isolator (CCA020D) mechanical drawing. All dimensions in millimeters.

Table 7.15: EMUS G1 Bottom Isolator (CCA020D) wire assignment

Pin No.	Wire Color	Assignment
1	Black	GND
2	Brown	IN
3	Black	BOT CELL –
4	Green	DN

7.3.1.3 CAN Cell Group Module

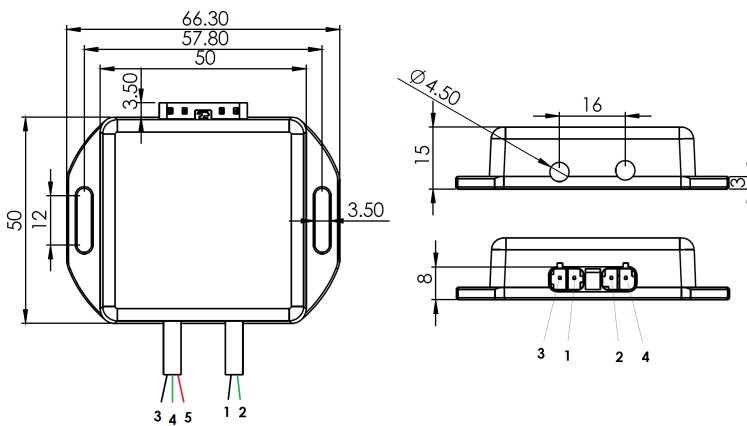

Figure 7.12: EMUS G1 CAN Cell Group Module (CGM020A) mechanical drawing. All dimensions in millimeters.

Table 7.16: EMUS G1 CAN Cell Group Module (CGM020A) cell communication wire assignment

Wire No.	Wire Color	Assignment
1	Black	BOT CELL –
2	Green	DN
3	Black	TOP CELL –
4	Green	UP
5	Red	TOP CELL +

Table 7.17: EMUS G1 CAN Cell Group Module (CGM020A) connector pin assignment

Pin No.	Assignment	Mating Housing	Terminal
1	GND	TE Connectivity 2106135-4	TE Connectivity 2106123-2
2	CAN H		
3	PWR		
4	CAN L		

7.3.2 Electrical characteristics

Table 7.18: EMUS G1 Top Isolator (CCA010D) electrical characteristics

Item	Value
Isolation voltage	2.0 kV
Transient/overvoltage protection between GND and OUT	6.2 VDC
Reverse polarity protection between GND and OUT	-0.7 VDC
Transient/overvoltage protection between TOP CELL – and UP	5.6 VDC
Reverse polarity protection between TOP CELL – and UP	-0.7 VDC
Transient/overvoltage protection between TOP CELL – and TOP CELL +	5.6 VDC
Reverse polarity protection between TOP CELL – and TOP CELL +	-0.7 VDC

Table 7.19: EMUS G1 Bottom Isolator (CCA020D) electrical characteristics

Item	Value
Isolation voltage	2.0 kV
Transient/overvoltage protection between GND and IN threshold	6.2 VDC
Reverse polarity protection between GND and IN limit	-0.7 VDC
Transient/overvoltage protection between BOT CELL – and DN threshold	6.2 VDC
Reverse polarity protection between BOT CELL – and DN limit	-0.7 VDC

Table 7.20: EMUS G1 CAN Cell Group Module (CGM020A) electrical characteristics

Item	Conditions	Value
Supply voltage		9.0 VDC to 32.0 VDC (24 VDC Typical)
Power supply reverse protection		Yes
Current consumption	In active mode, supply voltage = 12VDC	6.3 mA
	In active mode, supply voltage = 24VDC	3.6 mA
	In sleep mode, supply voltage = 12VDC	1.0 mA
	In sleep mode, supply voltage = 24VDC	0.16 mA
Isolation voltage		2.0 kV
Transient/overvoltage protection between TOP CELL– and UP		5.6 VDC

Reverse polarity protection between TOP CELL– and UP		-0.7 VDC
Transient/overvoltage protection between TOP CELL– and TOP CELL+		5.6V V DC
Reverse polarity protection between TOP CELL– and TOP CELL+		-0.7 VDC
Transient/overvoltage protection between BOT CELL– and DN		5.6 VDC
Reverse polarity protection between BOT CELL– and DN		-0.7 VDC
CAN Speed		50kbps, 125kbps, 250kbps, 500kbps, 800kbps, 1Mbps
Transient/overvoltage protection between CAN H/CAN L and GND (and vice versa)		24 VDC

7.3.3 Other specifications

Table 7.21: EMUS G1 Top and Bottom Isolator other specifications

Item	Value	
	CCA010D	CCA020D
Operating temperature	-40 to +85 °C	
IP rating	IP67	
Weight	13.6 g	10.5 g
Wire length	0.2 m	
Wire ring terminal type	Molex 19323-0011 (recommended crimp tool Molex 64003-0100 or PRESSMASTER KWB0325S)	

Table 7.22: EMUS G1 CAN Cell Group Module other specifications

Item	Conditions	Value
Max number of Cell Modules in cell communication daisy chain		254
Reserved CAN IDs		0x1FFFFEE5, 0x1FFFFEE6, 0x1FFFE5E5, and 0x1FFFE5E6
Sleep mode timeout		10 s
Wakeup source		CAN activity
Operating temperature		-20 to +70 °C
IP rating		IP53
Weight	Without CAN cable	56 g
	With CAN cable	91 g
Cell communication cable length		0.5 m
Cell communication wire ring terminal type		Molex 19323-0011 (recommended crimp tool Molex 64003-0100 or PRESSMASTER KWB0325S)
CAN cable length		1 m

7.4 Current Sensor

7.4.1 Mechanical specification

7.4.1.1 Bus Bar Type

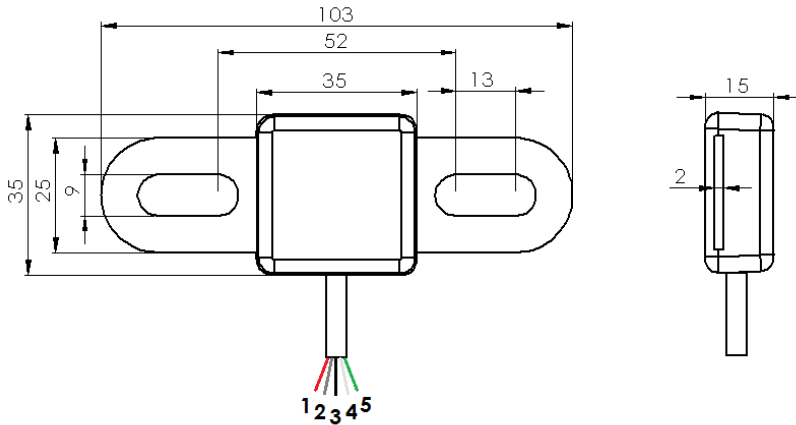

Table 7.23: EMUS G1 Bus Bar Type Dual Range Current Sensor (CS010C) wire assignment

Wire No.	Wire Color	Assignment
1	Red	+5V
2	Grey (shield)	GND
3	Black	CHANNEL 3
4	White	CHANNEL 2
5	Green	CHANNEL 1

Figure 7.13: EMUS G1 Bus Bar Type Dual Range Current Sensor (CS010C) mechanical drawing. All dimensions in millimeters.

7.4.1.2 Closed Loop Type

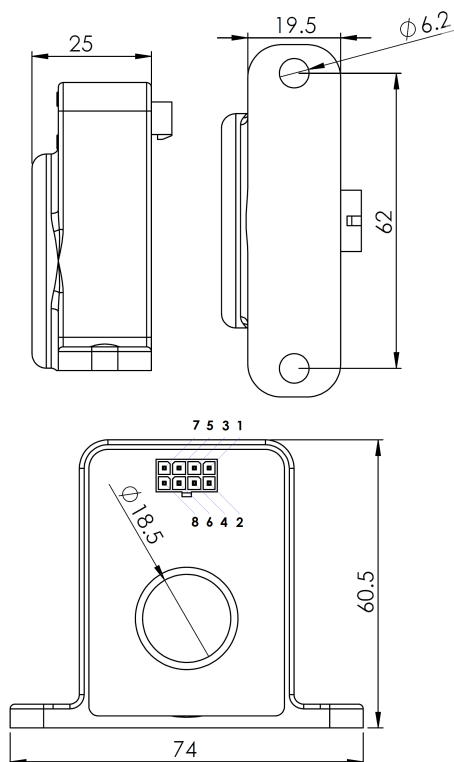

Table 7.24: EMUS G1 Closed Loop Type Dual Range Current Sensor (CS020A) connector pin assignment

Pin No.	Assignment	Mating Housing	Terminal
1	N.C.	TE Connectivity 794617-8 or equivalent	TE Connectivity 794610-1 (recommended crimp tool TE Connectivity 91501-1)
2	N.C.		
3	GND		
4	+5V		
5	CHANNEL 3		
6	N.C.		
7	CHANNEL 1		
8	CHANNEL 2		

Figure 7.14: EMUS G1 Closed Loop Type Dual Range Current Sensor (CS020A) mechanical drawing. All dimensions in millimeters.

7.4.2 Electrical characteristics

Table 7.25: EMUS G1 Dual Range Current Sensor electrical characteristics

Item	Conditions	Value	
		CS010B	CS020A
Nominal current measuring range		±500 A	±800 A
Peak current measuring range	Short bursts with less than 2% duty	±1000 A	±1200 A
Accuracy	When calibrated, at room temperature	0.5 %	
Supply voltage		5.0 VDC	
Current consumption	At typical supply voltage	21.0 mA	19.5 mA
Isolation voltage		>1.0 kV	
Conductor resistance		40 μΩ	-

7.4.3 Other specifications

Table 7.26: EMUS G1 Dual Range Current Sensor other specifications

Item	Value	
	CS010C	CS020A
Operating temperature	-30 to +80 °C	
IP rating	IP53	IP54
Weight	90 g	107 g (141 g with cable)
Signal cable length	1.5 m	1.0 m

7.5 Solid State Relay (obsolete product)

7.5.1 Mechanical specification

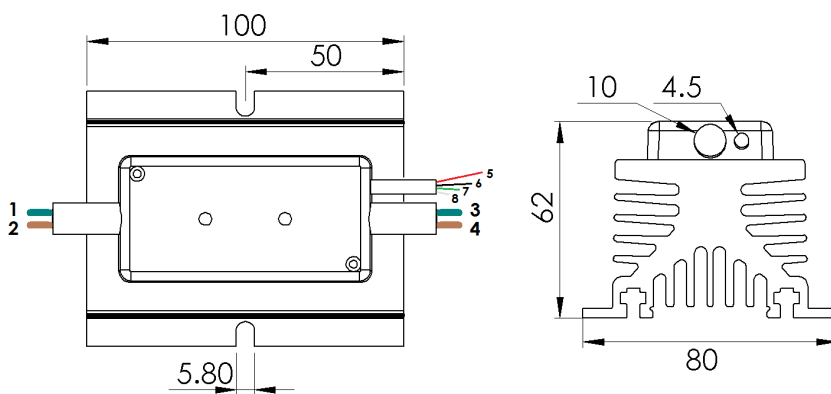

Figure 7.15: EMUS G1 Solid State Relay mechanical drawing. All dimensions in millimeters.

Table 7.27: EMUS G1 Solid State Relay wire assignment

Wire No.	Wire Color	Assignment
1	Teal	ACN IN
2	Brown	ACL IN
3	Teal	ACN OUT
4	Brown	ACL OUT
5	Red	+12V
6	Black	GND
7	Green	CHARGER
8	White	AC SENSE

7.5.2 Electrical characteristics

Table 7.28: EMUS G1 Solid State Relay electrical characteristics

Item	Conditions	Value
Switched voltage amplitude		110 to 230 VAC
Switched voltage frequency		50 to 60 Hz
Max switched current		16 A
Control circuit supply voltage		8.0 VDC to 16.0 VDC (12 VDC typical)
CHARGER input ON voltage		0 VDC
CHARGER input OFF voltage		= Supply voltage
AC SENSE output voltage	ACN IN and ACL IN connected to grid	= Supply voltage
	ACN IN and ACL IN not connected	0 VDC
Control circuit current consumption	In ON state, at typical supply voltage	7.7 mA
	In OFF state, at typical supply voltage	0 mA
Isolation voltage		3.75 kV

7.5.3 Other specifications

Table 7.29: EMUS G1 Solid State Relay other specifications

Item	Value
Operating temperature	-30 to +85 °C
IP rating	IP53
Weight	0.8 kg
AC IN cable length	1.5 m
AC OUT cable length	0.5 m
Signal cable length	1.5 m

7.6 Smartphone Connectivity Module

7.6.1 Mechanical specification

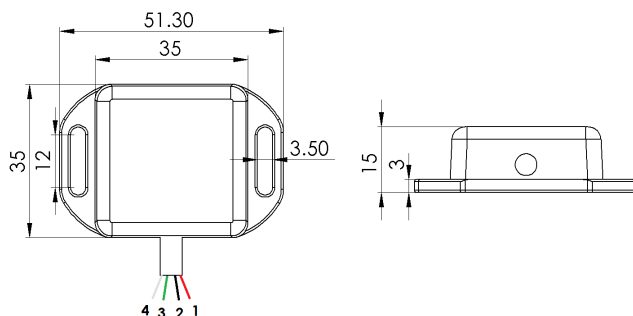

Figure 7.16: EMUS G1 Smartphone Connectivity Module mechanical drawing (applies to both SCM010B and BTM020E models). All dimensions in millimeters.

Table 7.30: EMUS G1 Smartphone Connectivity Module wire assignment (applies to both BTM010B and BTM020E models)

Wire No.	Wire Color	Assignment
1	Red	PWR
2	Black	GND
3	Green	RS232 RX
4	White	RS232 TX

7.6.2 Electrical characteristics

Table 7.31: EMUS G1 Smartphone Connectivity Module electrical characteristics

Item	Conditions	Value	
		BTM010B	SCM030A
Supply voltage		8.0 to 16.0 VDC (12.0 VDC typical)	9.0 to 32.0 VDC (24.0 VDC typical)
Power supply reverse polarity protection		Yes	
Current consumption	At typical supply voltage	34 to 52 mA	4.4 to 9.0 mA
RS232 transceiver		MAX3232	

7.6.3 Other specifications

Table 7.32: EMUS G1 Smartphone Connectivity Module other specifications

Item	Value	
	BTM010B	BTM020E
Smartphone BT protocol version	2.0 + EDR	
Communication range	10 m	
Operating temperature	-30 to +85°C	
IP rating	IP53	
Weight	60 g	
Cable length	1.5 m	

7.7 Display Unit

7.7.1 Mechanical specification

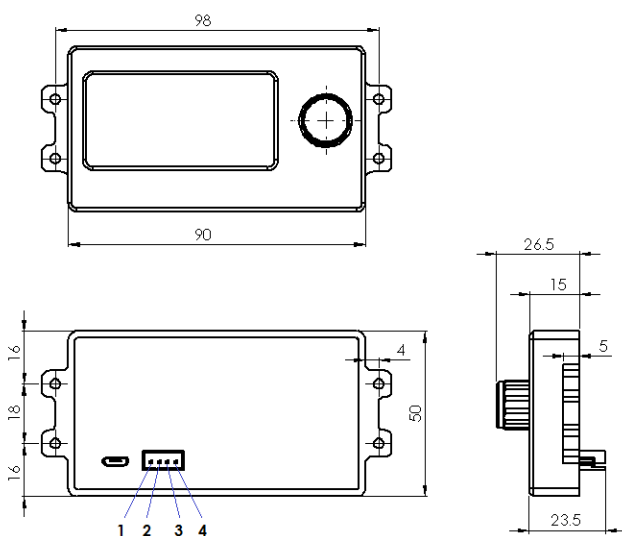

Figure 7.17: EMUS G1 Display Unit (DU010A) mechanical drawing. All dimensions in millimeters.

Table 7.33: EMUS G1 Display Unit connector pin assignment

Pin No.	Assignment	Mating Housing	Terminal
1	PWR	Weli Sheng P4-I25019	Weli Sheng I25019PS-2
2	RS232 RX		
3	RS232 TX		
4	GND		

7.7.2 Electrical characteristics

Table 7.34: EMUS G1 Display Unit electrical characteristics

Item	Conditions	Value
Supply voltage		9 to 32 VDC (24 VDC typical)
Power supply reverse polarity protection		Yes
Current consumption	Supply voltage = 12 VDC	30 mA
	Supply voltage = 24 VDC	15 mA
USB controller		FT232R
RS232 transceiver		MAX3232

7.7.3 Other specifications

Table 7.35: EMUS G1 Display Unit other specifications

Item	Value
Operating temperature	-10 to +60 °C
IP rating	IP54
Weight	94 g (158 g with cable)
Display type	OLED
Display color	White
Screen resolution	128 × 64
Screen size	2.42"
Screen brightness	60 - 80 cd/m ²
Screen contrast	10000 : 1
Viewing angle	173 °
Cable length	2.0 m

We appreciate your inputs. In case you have noticed some mistakes, have some suggestions on how to improve this document, or simply have more questions, please contact us.

EMUS, UAB
Zirmunu 68, 09124, Vilnius, Lithuania
Company code: 302542629

sales@emusbms.com
support@emusbms.com
www.emusbms.com