



# Smartphone Connectivity Module

Product Code: SCM031B

## Introduction

The **Smartphone Connectivity Module** is a low energy adapter that allows you to wirelessly monitor various battery parameters in real time on any Android device using Emus EVGUI app, or any PC running Windows operating system, using an USB dongle. The Smartphone Connectivity Module connects to the main controller using RS232 interface. A compatible EMUS EVGUI App is available on Google Play downloads section free of charge.



## Applications

- Android 4.4 or later
- All Windows OS versions with BLED112 USB dongle

## Features

- RS232 interface which connects EMUS Smartphone
- Low energy BT protocol which allows monitor and configures EMUS G1 Control Unit parameters by smartphone, tablet or Windows PC using BLED112 USB dongle

## Mechanical Information

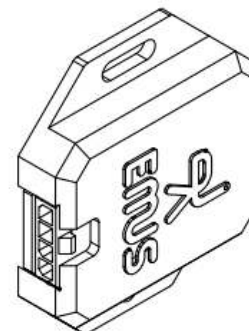
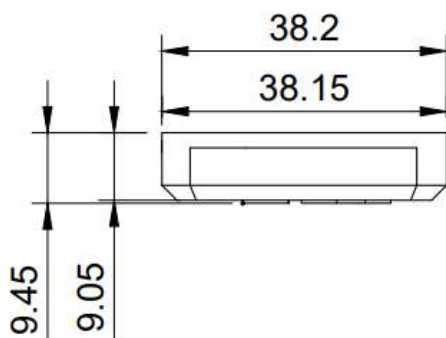
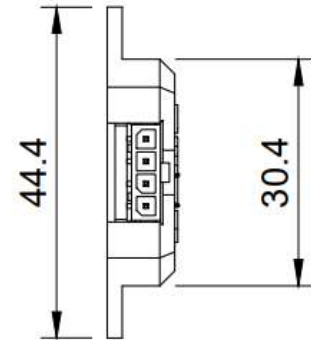
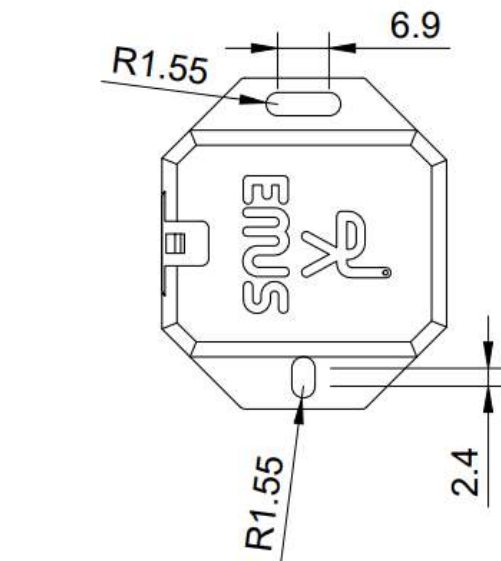



# Smartphone Connectivity Module

Product Code: SCM031B

Table 1. SCM031B pin assignment

Pin No.	Wire Color	Assignment	Mating Housing	Terminal	Emus G1 BMS Control Unit pins
1	Black	GND	Molex 43645-0400	43030-0003 (recommended crimp tool Molex Hand Crimp Tool P/N: 638190000)	GND
2	White	RS232 RX			DISP. TX
3	Green	RS232 TX			DISP. RX
4	Red	PWR			PWR

## Electrical Characteristics

Table 2. SCM031B electrical characteristics

Item	Conditions	Value
Supply voltage	-	9.0 to 32.0 VDC (24.0 VDC typical)
Power supply reverse polarity protection	-	Yes
Current consumption	At typical supply voltage	4.4mA to 9.0 mA

## Other Specifications

Table 3. SCM031B other specifications

Item	Value
Smartphone BT protocol version	4.0 LE
Communication range	10 m
Operating temperature	-40 to +85°C
IP rating	IP53
Weight	60 g
Cable length	1.5 m

## Application

